

Instruction Manual for the

Estate SWING

E-SU 2200 / E-SU 2202 Series



!Warning!

Read all instructions before beginning installation or use of this gate opener.

This operator exerts a high level of force.

Exercise caution at all times and stay clear of the system during operation.

Manufactured by

FAAC

An ISO 9001 Certified Company

CE DECLARATION OF CONFORMITY OF MACHINES

(Directive 89/392/EEC, Annex II, Part B)

Manufacturer: FAAC S.p.A.

Address: Via Benini, 1 – 40069 Zola Predosa Bologna – Italy

Declares that: ROLLER 24 A.K.A. Estate Swing (USA) mod operator

- Is built to be integrated into a machine or to be assembled with other machinery to create a machine under the provisions of Directive 89/392/EEC, and subsequent amendments 91/368/EEC, 93/44/EEC.
- Conforms to the essential safety requirements of the following EEC directives:
 - 73/23/EEC and subsequent amendment 93/68/EEC, 89/336/EEC and subsequent amendment 92/31/EEC and 93/68/EEC.
 - And also declares that it is prohibited to put into service the machinery until the machine in which it will be integrated or of which it will become a component has been identified and declared as conforming to the conditions of Directive 89/392/EEC and subsequent amendments assimilated under national laws under DPR #459 of July 24, 1996.

Bologna, January 1, 2002

Managing Director
A. Bassi



Warnings for the installer General safety obligations

1. Attention! To ensure the safety of people, it is important that you read all the following instructions. Incorrect installation or incorrect use of the product could cause serious harm to people.
2. Carefully read the instructions before beginning to install the product.
3. Store these instructions for future reference.
4. This product was designed and built strictly for the use indicated in the documentation. Any other use, not expressly indicated here, could compromise the good condition/operation of the product and/or be a source of danger.
5. FAAC declines all liability caused by improper use or use other than that for which automated system was intended.
6. Do not install the equipment in an explosive atmosphere; the presence of inflammable gas or fumes is a serious danger to safety.
7. The mechanical parts must conform to the provisions of Standards EN 12604 and EN 12605.

For non-EU countries, to obtain an adequate level of safety, the standards mentioned above must be observed, in addition to national legal regulations.

8. FAAC is not responsible for failure to observe Good Technique in the construction of the closing elements to be motorized, or for any deformation that may occur during use.
9. The installation must conform to Standards EN 12453 and EN 12445.

The safety level of the automated system must be C+D.

10. Before attempting any job on the system, cut out electrical power and disconnect the batteries.
11. The main power supply of the automated system must be fitted with an all-pole switch with contact opening distance of 3 mm or greater. Use of a 6A thermal breaker will all-pole circuit break is recommended.
12. Make sure that a differential switch with threshold of 0.03 A is fitted upstream of the system.
13. Make sure that the earthing system is perfectly constructed, and connect metal parts of the means of the closure to it.
14. The automated system is supplied with an intrinsic anti-crushing safety device consisting of a torque control. Nevertheless, its tripping threshold must be checked as specified in the Standards indicated at point 10.
15. The safety devices (EN 12978 standard) protect any danger areas against mechanical movement risks, such as crushing, dragging, and shearing.
16. Use of at least one indicator-light (e.g. FAACLIGHT 12VDC) is recommended for every system, as well as a warning sign adequately secured to the frame structure, in addition to the devices mentioned at point "15".
17. FAAC declines all liability as concerns safety and efficient operation of the automated system, is system components not produced by FAAC are used.
18. For maintenance, strictly use original parts by FAAC.
19. Do not in any way modify the components of the automated system.
20. The installer shall supply all information concerning manual operation of the system in case of an emergency, and shall hand over to the user the warnings handbook supplied with the product.
21. Do not allow children or adults to stay near the product while it is operating.
22. Keep remote controls or other pulse generators away from children, to prevent the automated system from being activated involuntarily.
23. Transit through the leaves is allowed only when the gate is fully open.
24. The user must not attempt any kind of repair or direct action whatever and contact qualified personnel only.
25. Do not short-circuit the poles of the batteries and do not try to recharge the batteries with power supply units other than Master or Slave cards.
26. Do not throw exhausted batteries into containers for other waste but dispose them in the appropriate containers to enable them to be recycled.
27. **Anything not expressly specified in these instructions is not permitted.**

Estate Swing Summary of Functions

The Estate Swing is only to be used for vehicular swing gates in a Class I setting.

Class I: A vehicular gate opener (or system) intended for use in a home of one-to-four single family dwelling, or a garage or parking area associated therewith.

The FAAC Estate Swing automated system was designed and built for controlling vehicle access. Do not use for any other purpose.

The external automation with geared motor automates residential swing-leaf gates with leaves of up to 12' in length, and is ideal for applications in which discretion is of great importance as it is a completely underground unit. It has the ability to be opened 180-degrees and works great with any type of gate mounting. The irreversible system ensures the gate is mechanical locked when the motor is not operating. A lock still needs be installed if security of high winds are a concern. A manual release makes it possible to move the gate in the event of a power-cut or fault.

For Your Assistance

Keep this manual safely stored after installation.

Serial Number _____

Date of Purchase _____

Place of Purchase _____

Have this information on hand while handling all service and warranty issues.

The table of contents are listed to assist you locating a desired section. We do however strongly suggest studying every page of the instruction manual before attempting installation.

Table of Contents

	PAGE(S):	
• Specifications of the Estate Swing and Components	1	
• System Overview & Preliminary Checks	2	!
• Manual Operation, Restoring Automation	3	!
• Setting the Foundation	4-5	!
• Setting the Gate	6	!
• Installation of Operator	7	
• Power	8	!
• Control Board Overview	9-10	!
• LED Lights and Operational Displays	11	
• Programming Operating Parameters	12	!
• Operating Parameters Chart	13-14	
• Programming Gate Movements	15-16	
• Photocell and Safety Device Guide	17	
• Installing Receiver and Setting Transmitters	18	
• Troubleshooting	19-21	!
• Accessories	22	



Marks pages with opener or usage warnings. Although we have marked these as very important warnings, **please read the entire manual.** Every step is important to the correct installation of your gate opener.

Specifications

MODEL	Estate Swing
Power Supply	115V AC/ 24V AC
Rated Absorbed Power (W)	80
Current drawn (A)	4.5
Rpm Electric Motor	1500
Cycles per hour	Continuous Duty / Approx. 50
Operating Ambient Temp	-4 to 131 F
Protection class	IP67
Gate leaf max length (ft.)	Up to 12
Gate leaf max weight (lbs.)	Up to 1100
Operator overall dimensions LxHxD(in.)	See below (approximate)
Operator Weight + Foundation Box	27 lbs + 32 lbs

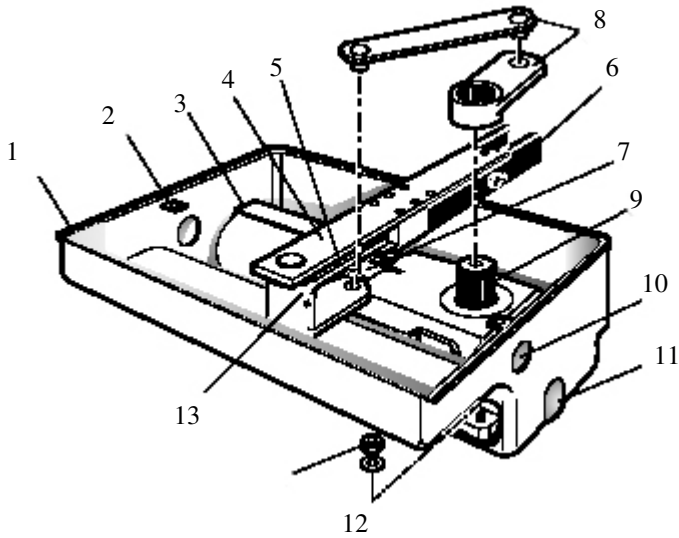

- 1) Foundation Box
- 2) Bores for fastening cover
- 3) Operator
- 4) Support bracket for gate
- 5) Locking bracket
- 6) Release device with key
- 7) Operator earth connection
- 8) Crank and connecting rod assembly
- 9) Pinion
- 10) Bore for power supply
- 11) Bore for drain pipe
- 12) Fastening screws
- 13) Lubrication bore

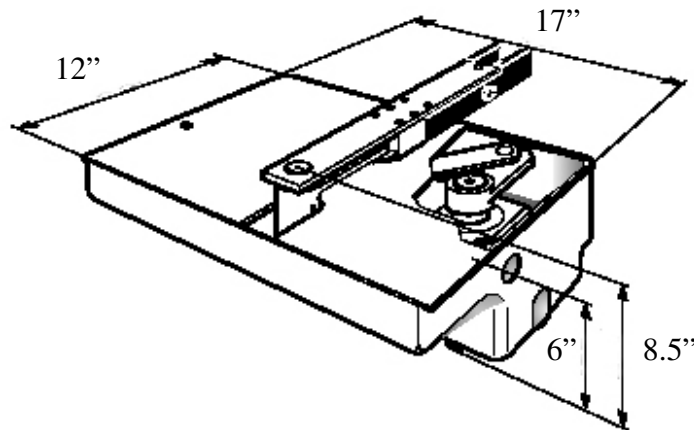

Standard System Overview and Safety Zones

The system display to the below is a recommended standard system. Other approved accessories can be installed. Photo sensors and a flashing light indicating gate movement is recommended for safety purposes.

- 1,2 Estate Swing Operator
- 3 Photocells (not included)
- 4 Control board
- 5 N/A
- 6 Push button opening device (not included)
- 7 Receiver extension (not included)
- 8 12Vdc flashing lamp (not included)
- 9 Positive stop
- 10 DC transformer



- Notes:**
- 1) When laying electrical cables, use appropriate rigid and/or flexible tube
 - 2) Do not run any wires in the same conduit as 110 AC power that may be in the area. This will cause unwanted interference

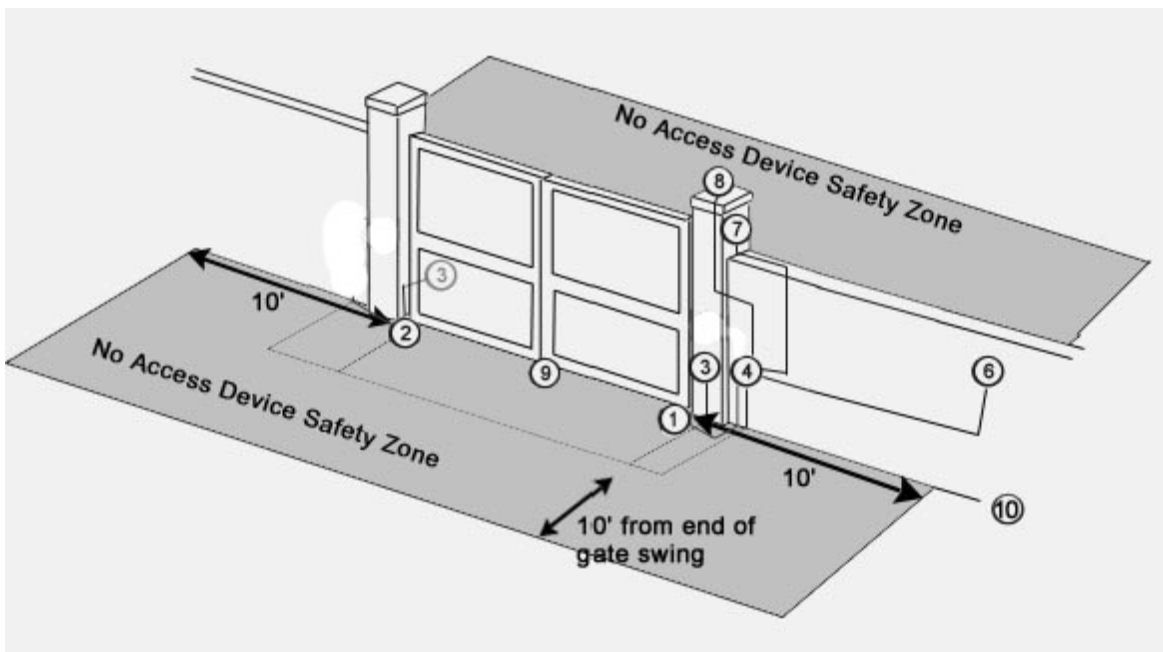

IMPORTANT Preliminary Checks:

To ensure safety and an efficiently operating automated system, make sure the following conditions are observed.



- **Set up physical stop points for full open and full closed. This is mandatory for this operator.**
 - The gate and post must be suitable for being automated. Check that the structure is sufficiently strong and rigid, and its dimensions and weights conform to those indicated on page 1.
- Make sure the leaves move smoothly without any irregular friction during entire travel.
- Make sure the hinges are in good condition. Ball bearing hinges are ideal for gates weighing over 200 lbs. or over 10' in length.
- Make sure the gate is plumb and level.
- The fence post must be secured in the ground with concrete. This will prevent alteration of alignments and leveling during installation and during cycles.

Manual Operation Mode

- 1) Pull lock cover back.
- 2) Insert and turn provided key. Turn the key in the direction of the post as far as it will go.
- 3) Pull the lever out.
- 4) The gate should now be free of the operator lever.

To exit manual mode, reverse the above steps.

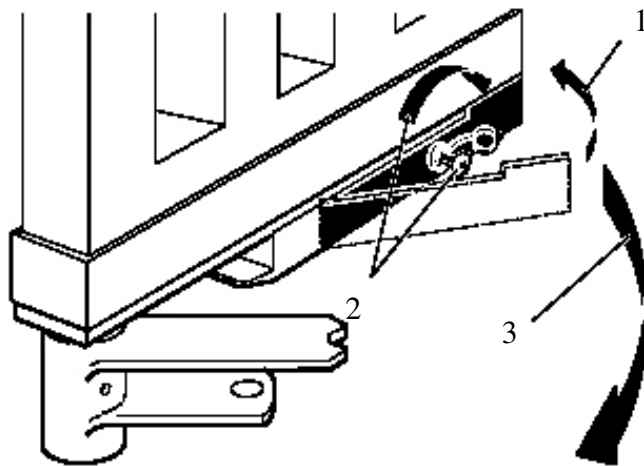

Never lubricate the release system for any reason.

Setting the Foundation Box

1. Position your gate for installation. There are three different scenarios for gate positioning:

- If you have an existing gate with fixed hinges, remove the gate and the bottom hinge. If the gate cannot be removed, place blocks under its bottom edge to support it.
- If you have an existing gate with adjustable hinges, remove the bottom hinge, slacken the top hinge and swing the leaf around the axis of the top hinge (see picture to right).
- If you have a new gate to be installed, fit the top hinge. If possible use an adjustable hinge.

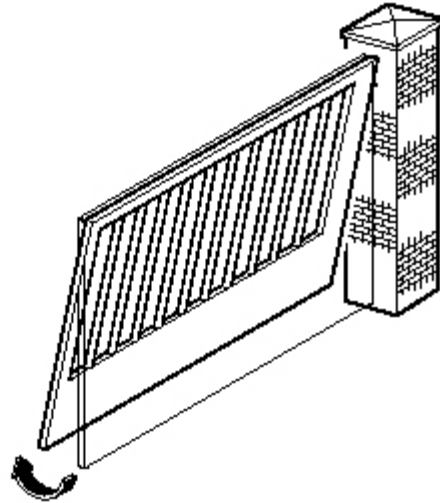

2. Dig out a hole for the foundation box, depending on the nature of the ground it may be necessary to cast a bed of quick-setting concrete at the bottom of the hole to avoid movement in the future.

3. Study the below diagrams carefully and design your system to match the diagrams. **The center of the pivot on the foundation box must be perfectly aligned with the leaf's axis of swing.**

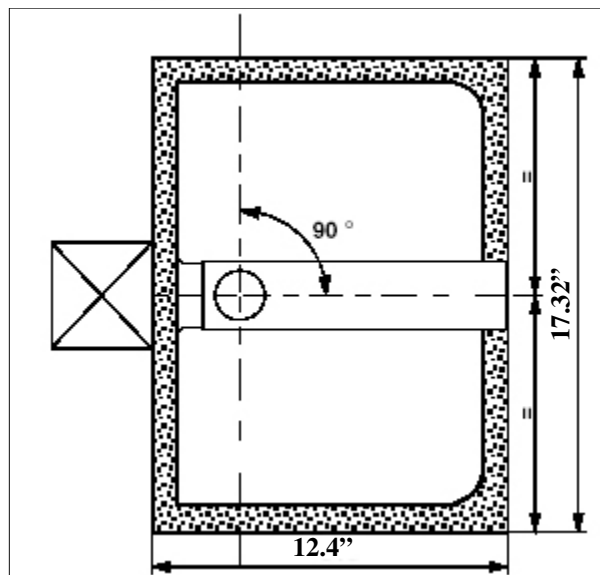
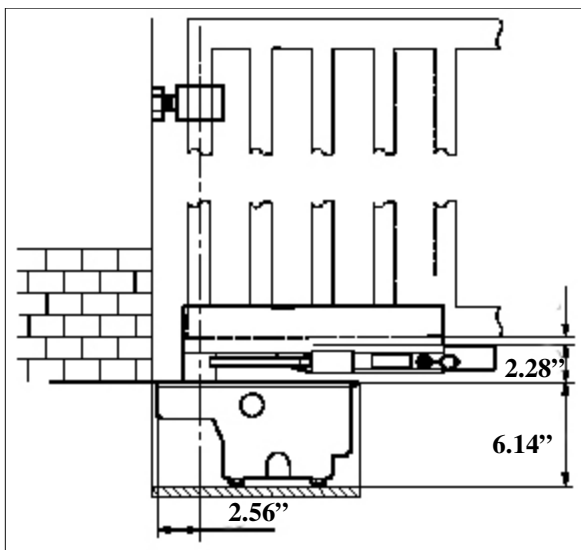
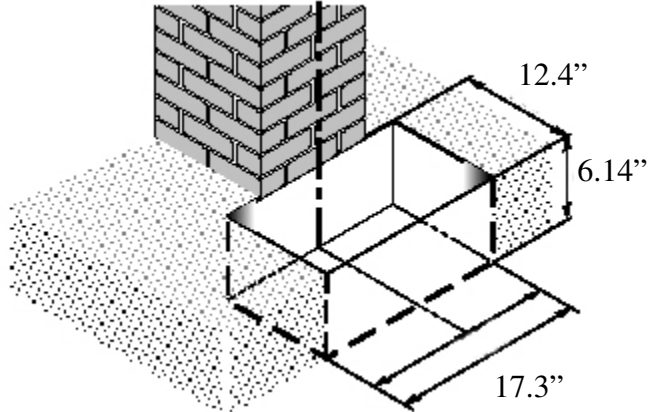

4. After the foundation box is mounted according to the previous page, it is time to run PVC for power and drainage. Lay down a PVC tube with a diameter of 1.38". This tube will be used for power and will lead to the control box. Lay a second tube to drain off rain water from the box to the nearest drain.

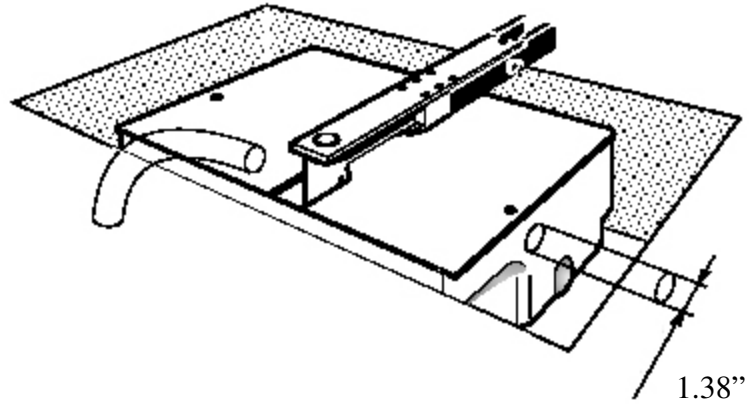

5. Set the foundation box in concrete.

Setting up the Gate

Important: Wait until the cement from the previous step is completely set before beginning this stage of installation.

1. Assemble the release levers on the support bracket and fit the bracket on the pivot in the foundation box, also inserting the ball bearing in between the bracket and pivot.

NOTE: Lubricate the ball bearing, but DO NOT lubricate the release system for any reason.

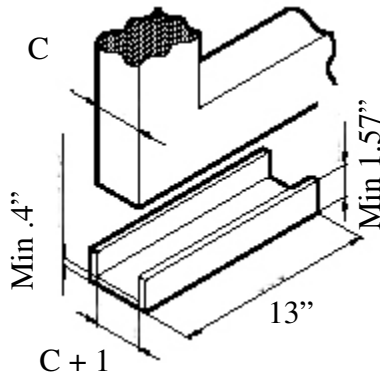
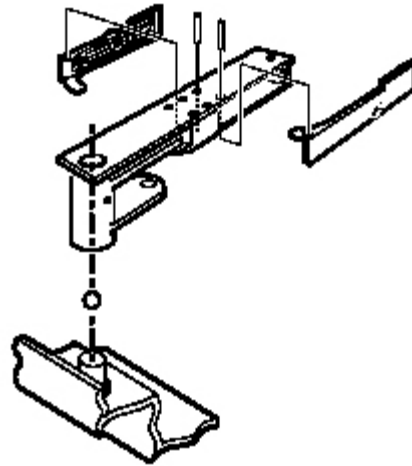

2. Create a guide bracket for your gate. The materials for this piece do not come with the unit. Every gate has different dimensions and require different guide brackets.

The axis of rotation for the opener should match the axis of rotation for the gate. (Meaning the center of the pivot in the foundation box must align with the center of the hinge of the gate.) This may mean different positioning of the gate in the guide bracket. Below are examples of guide bracket set ups.

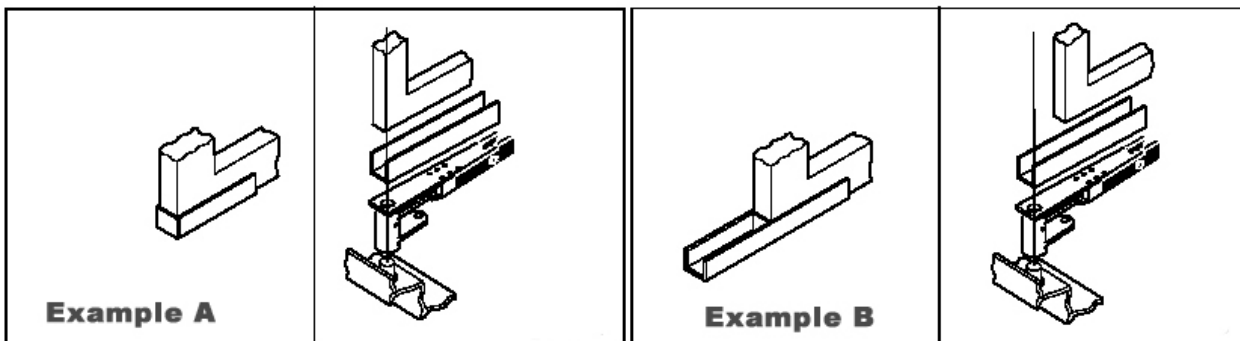

3. Weld the guide bracket to the support bracket. Fit the gate into the guide bracket and put the top gate hinge in place.



NOTE: Only weld the guide racket to the support bracket. Never weld the gate to the guide or support bracket. This will ensure trouble free operation.

Installing the Opener

1. Open the gate leaf.
2. Place the operator on the fastening screws on the foundation box and fix it by using the supplied nuts and washers.
3. The position of the motor must be as shown below. The pinion must be on the opposite side of the leaves opening direction.

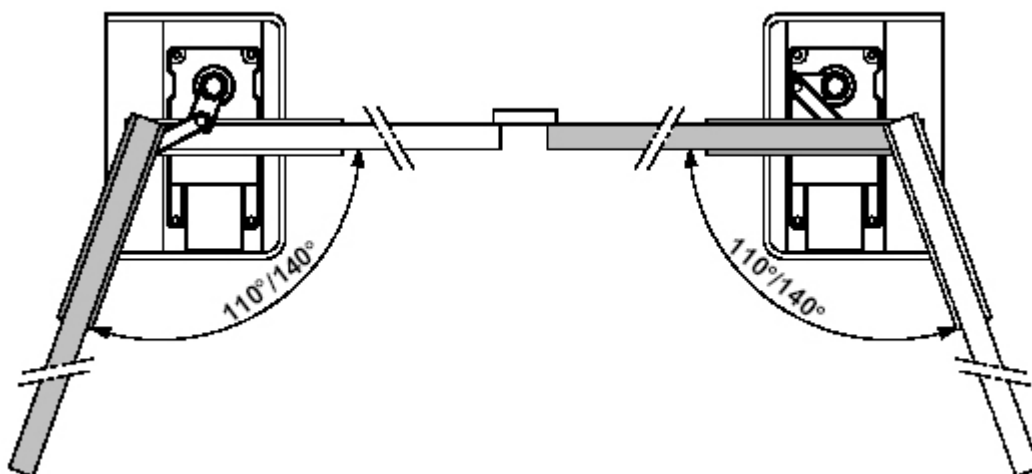

4. Manually close the leaf and fit the driving levers supplied, as seen below. Use the appropriate lever for the degree of opening you will be using.

Up to 110-Degrees

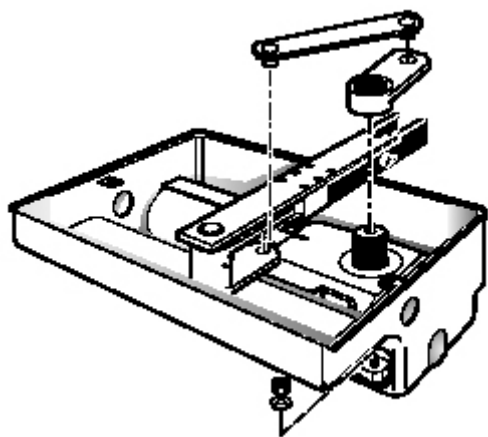

Over 110-Degrees

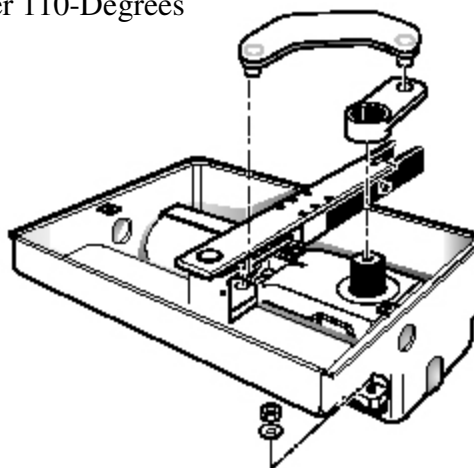

5. Lubricate pinions and the pivots of the two levers. **NEVER lubricate the release system.**

Power

1. The Estate Swing E-SU 2200 comes with 1) 24V transformer. The transformer supplied has 2 screw terminals to connect to. You may locate the transformer up to **124' (single) or 62' (dual) away from the control board using 2 conductor stranded direct burial wire as specified below.**

Single (2200)

- 0-31 Feet - Use 16 Gauge
- 32-49 Feet - Use 14 Gauge
- 50-78 Feet - Use 12 Gauge
- 79-124 Feet - Use 10 Gauge

Dual (2202)

- 0-15 Feet - Use 16 Gauge
- 16-24 Feet - Use 14 Gauge
- 25-39 Feet - Use 12 Gauge
- 40-62 Feet - Use 10 Gauge

2. Insert the two wires from the transformer into the two VAC terminals on the control board (CN1). The wires are not polarized, there is no positive or negative. **Do not splice the power cable wire.**



Never run 110VAC power directly to the Estate Swing. This will destroy the Estate Swing control board.

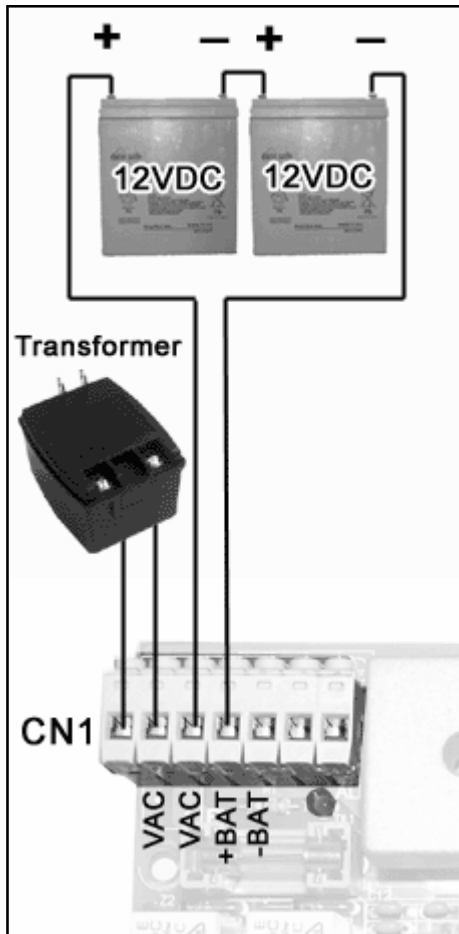

Never connect the power wire with the transformer plugged in. Contact between the two lead wires, even for a second, will destroy the transformer.

Transformers are only warranted if the internal fuse is not blown. If the fuse is blown an outside factor (shorting, surge, water, etc) has caused the transformer not to function.

3. Plug the **transformer** into a 110 V AC outlet.
4. The transformer is not weather proof and must be kept in a covered area. *Plug covers are available from your dealer, contact 1-800-640-GATE for a dealer in your area.*
5. Two 12V DC batteries may be run in series as backup to the 24V transformer power. Running two 12V batteries (Max 5 a/h per battery) in series creates 24V system, **you cannot run them in parallel (see diagram to the left)**
6. The power light located below the +24V and -24V output terminals will be on if the power is connected properly. If the light is off then power through the transformer is not functioning properly and either the unit has no power or is on battery backup. *The light stays off during battery backup.*

transformer is not functioning properly and either the unit has no power or is on battery backup. *The light stays off during battery backup.*

Control Board Overview



Caution! Do not run 110V AC power direct to the board. This will cause permanent damage to both boards and void your warrantee. **Caution!**

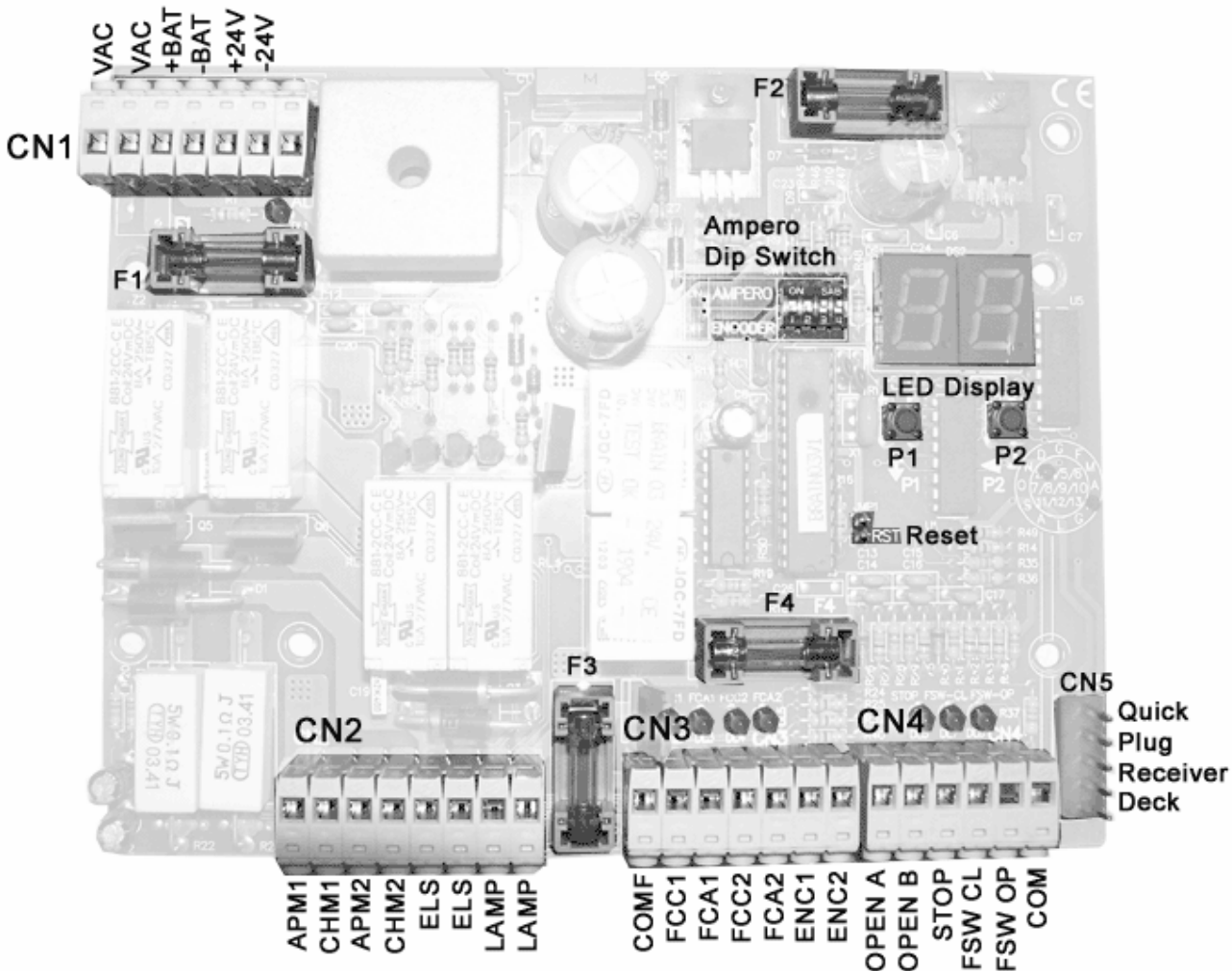

CN1 - Upper left hand corner of board, used for power and back up power.

- **VAC - terminals.** The input terminals for the supplied 24V transformer. Polarity is not an issue for this terminal.
- **+BAT, -BAT - terminals.** Input terminals for the optional backup batteries. The battery power coming in must be 24V DC. This can be achieved by running two 12V batteries (Max 5 a/h per battery) in series. During normal operation, the unit keeps the batteries charged and the batteries begin operating the unit if no power is being supplied through terminals VAC. Observe polarity on these terminals.
- **+24, -24 - terminals.** Accessories needing constant 24V power should be attached to these terminals following the correct polarity. (Example: Alternate receiver, exit wand)

Continued on following page.

CN2 - Located on the lower left side of the board, these terminals are outputs for the operator arm(s), gate locks (optional), and lamps (optional).

- **APM1, CHM1 - terminals.** For dual operations these terminals are for the arm that must move first, for single operations these terminals are the output for controlling the operator arm.
- **APM2, CHM2 - terminals.** For dual operations **ONLY**. Connect the arm that is to move second to these terminals. For single operations nothing should be connected to these terminals.
- **ELS - terminals.** Brief 12V output at beginning of operation cycle, meant for release an electric lock.
- **LAMP - terminals.** Both a flashing lamp and a courtesy lamp can be connected to these terminals with a power supply of 24V DC and a max output of 15 W. to change between flashing lamps and courtesy lamps, select parameter "G".

CN3 - Located on the center bottom of the board, these terminals are for limit switches.

- **COMF - Common terminal** to make the needed normally closed connections for the limit switches.
- **FCC1 - Normally closed contact.** This terminal is connected with the COMF through the limit switch. When tripped (connection opened) it stops the motion of the first operator. (*This terminal must be jumped with COMF*)
- **FCA1 - Normally closed contact.** This terminal is connected with the COMF through the limit switch. When tripped (connection opened) it stops the motion of the first operator. (*This terminal must be jumped with COMF*)
- **FCC2 - Normally closed contact.** This terminal is connected with the COMF through the limit switch. When tripped (connection opened) it stops the motion of the second operator. (*This terminal must be jumped with COMF*)
- **FCA2 - Normally closed contact.** This terminal is connected with the COMF through the limit switch. When tripped (connection opened) it stops the motion of the second operator. (*This terminal must be jumped with COMF*)
- **ENC1, ENC2 - terminals. NOT USED**

CN4 - Located on the bottom right of the board, these terminals are for accessories and safety devices.

- **OPEN A - terminal.** This is the most common terminal for accessories. Accessories utilizing a normally open contact to set the gate in motion will be attached to this terminal and the COM terminal (common or also know as ground).
- **OPEN B - terminal.** This terminal is for opening the first leaf only in dual gate operations. It is a normally open contact that must be used in conjunction with the COM terminal.
- **STOP - terminal.** This is a normally closed terminal that is used for gate motion stopping emergency commands. **If a safety device is not being used in this terminal the operator must have a jumper ran from this terminal to the COM terminal in order to operate.**
- **FSW CL, FSW OP - terminals.** These normally closed terminals are for safety devices during the closing (CL) and opening (OP) cycles of the gate. **If a safety device is not being used in this terminal the operator must have a jumper ran from this terminal to the COM terminal in order to operate.**
- **COM - terminal.** This is a common, or sometimes referred to as ground, terminal. It is used in conjunction will **ALL** accessories and safety devices.

LED Lights & Operational Displays

Control Board LED Lights - The control board LED lights are located above their respective terminals that they represent. (With exception of ALIM, power supply light, which is located below the power terminals in the upper left corner.) The LED lights are a quick way of verifying necessary connections are made. Below is a chart of their interpretations.

LED	ON	OFF
ALIM	Powers supply by transformer	Power supply by battery or no power
FCC 1	Motor 1 closing limit switch - jumped	Motor 1 closing limit switch - open
FCA 1	Motor 1 opening limit switch - jumped	Motor 1 opening limit switch - open
FCC 2	Motor 2 closing limit switch - jumped	Motor 2 closing limit switch - open
FCA2	Motor 2 opening limit switch - jumped	Motor 2 opening limit switch - open
STOP	Stop command - not activated	Stop command - activated
FSW CL	Closing safety device - not tripped	Closing safety device - tripped
FSW OP	Opening safety device - not tripped	Opening safety device - tripped

During idle AND OPERATION all LED lights should be on.

If not using safety devices , you must jump STOP, FSW CL and FSW OP to COM in order for the gate opener to function. You must also jump ALL FCC and FCA terminals to COMF.

Standard Operation Display - This is when the gate opener is not in parameter setting mode or programming mode. LED displays DS1 and DS2 will show the following:

Gate Status

— — Gate At Rest in Closed Position

 Gate Opening or Gate Open when Auto Close is OFF

 Gate open in pause status
(Only with automatic re-close enabled - Parameter c)

 Gate Closing

Programming Operating Parameters



Complete this step prior to programming the gate movements. This will dictate how your gate will react during programming.

Important Dip Switch Setting

Verify the 4 dipswitches to the left of the display LED are as follows:

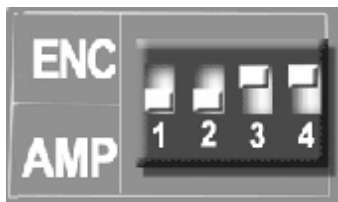

1. DOWN
2. DOWN
3. UP
4. UP

Entering programming mode

1. Make the necessary power connections and check the LED lights to be sure the appropriate lights are lit.
2. The display should show --
3. Press and hold down **P2** until the display shows parameter A with the corresponding number that is currently default or previously programmed.
4. Press **P1** to change the number variable of the parameter, **USE THE CHART ON THE NEXT PAGE AS A GUIDE.**
5. To move to the next parameter, Press **P2**.
6. When 60 seconds have elapsed without any button being pressed the control unit automatically exits the programming mode. To exit manually, Press **P2** to scroll through all the parameters until the display shows --

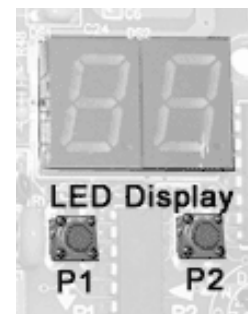

Operating Parameters Chart

<u>A 1</u>	Minimum Force	FORCE	This parameter adjusts the sensitivity of the electronic clutch system. The electronic clutch system controls the anti-crushing auto-reverse feature when a gate in motion makes contact with an obstacle.
<u>A 2</u>	Medium-low Force		
<u>A 3</u>	Medium-high Force		
<u>A 4</u>	High Force		
<u>b 1</u>	1.5 Second Offset	DELAY	This parameter is for Dual gate opener systems ONLY. This determines how long the second leaf will pause before moving to allow the first leaf to separate and avoid obstructing on the other leaf. If using a Single gate opener system, the setting will not affect your gate.
<u>b 2</u>	3 Second Offset		
<u>b 3</u>	6 Second Offset		
<u>b 4</u>	10 Second Offset		
<u>c 0</u>	Disabled	AUTO-RECLOSE	This parameter turns auto-close on or off. The pause time for the auto-close is set during movement programming.
<u>c 1</u>	Enabled		
<u>d 0</u>	Opens/Closes/Opens...	OPEN A	This parameter determines what an OPEN A terminal command will result in. d1 is recommended for safety.
<u>d 1</u>	Opens/Stops/Closes/Stops...		
<u>E 0</u>	Disabled	CONDO	This parameter is for use with multiple gate users. If enabled, when the gate is opening it can not be reversed by another open signal.
<u>E 1</u>	Enabled		
<u>F 0</u>	Disabled	OVER-PUSH	This parameter is for use with electric gate locks. The gate will briefly push further closed before opening to allow the lock to release.
<u>F 1</u>	Enabled		
<u>G 0</u>	Flashing Lamp	LAMP	This parameter is to determine between a flashing or steady lamp. If not using a lamp the setting will not affect your gate.
<u>G 1</u>	90 Second Courtesy Light		

Continued on following page.

$H \ 0$	20% of total arch	SOFT START/ STOP	This parameter determines when the gate will begin to slow down near the end of opening and closing cycle.
$H \ 1$	10% of total arch		
$I \ 0$	Low	SOFT SPEED	This parameter determines how fast the gate will move during the soft start/stop. If using positive stops it must be set to 0.
$I \ 1$	High		
$L \ 0$	No Limit Switch	LIMIT SWITCH	In this parameter you MUST specify whether you are using limit switches or not for proper function of your gate.
$L \ 1$	Limit Switch		
$N \ 1$	Single Leaf Gate	SINGLE OR DUAL	In this parameter you MUST specify whether you are using single gate (one leaf - one motor) or dual gate (two leaves - two motors).
$N \ 2$	Dual Leaf Gate		

Press P2 one more time to exit this mode.

After programming your last parameter you must now move on to programming your gate movement. Gate movement instructions begin on the next page.

Your opener arm(s) will not move prior to completing gate movement programming.

Programming Gate Movements

In this stage, your control board will memorize where your limits are (identified by limit switches, positive stops or both) in both opening and closing phases. Also if the auto-close feature is activated it will learn the user specified pause time.

1. Release the operator gears using the manual release process. Once released, manually move the gate(s) half way between the open and close stop points.

2. Relock the operator gears at the half way point through its cycle.

3. Verify your operator control board is showing **-- --** on the LED display by touching the TWO reset pins as in the graphic below.

HINT: Using a flat head screwdriver, place it between the two pins and turn until contact is made with both.

4. Press and hold down **P2** until the LED display shows the A parameter and the relevant number appear in the LED display.

5. Give an **OPEN A** command. This can be done with any opening device (keypad, push button, etc...) wired into OPEN A and COM or using the transmitter. *You can also briefly (one second or less) jump OPEN A and COM with a wire.* This will begin your gate in the **CLOSING DIRECTION** and the **LED display** will read **"Pr"**.

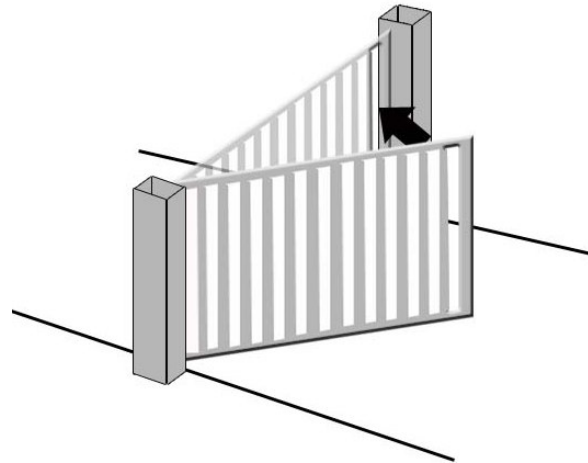
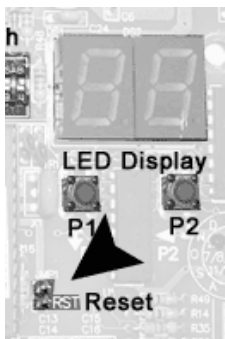
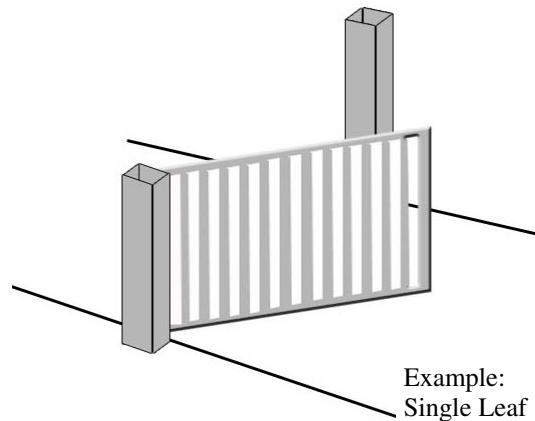

IMPORTANT: If the gate(s) begin to open rather than close, the gate(s) must be stopped with a reset pulse.

You can either:

Touch the TWO pins of the JMP "RESET" using a screwdriver **OR**
Disconnect all power (transformer and backup battery)

Then switch the wires leading into APM1-CHM1 (if Dual Operator APM2-CHM2 also) and then begin programming again.

5. When the closing stop point or limit switch is reached, the motor pauses for approximately 2 seconds, and then restarts with a total opening maneuver to the opening stop point or limit switch.

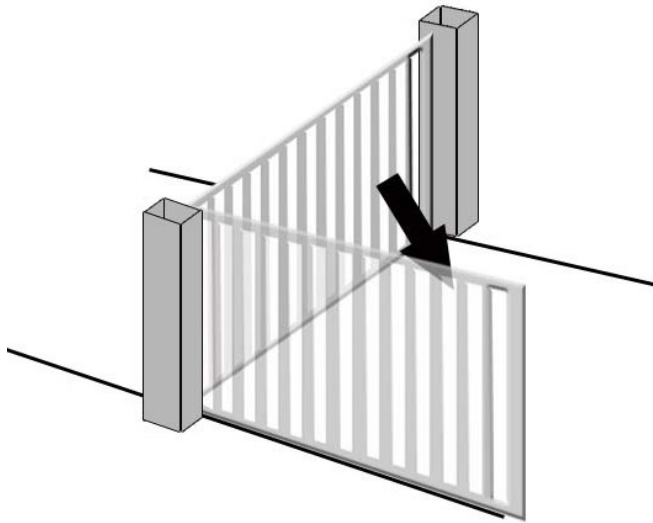

6. When the full open stop or limit switch is reached the gate(s) will stop.

7. Wait for the amount of time you would like your gate(s) to pause for during normal operation before automatically re-closing and then signal your opener using an OPEN A contact or transmitter signal to close the gate(s). The gate(s) will then return to closed and programming will be complete.

(Even if your auto close is off you must still set a pause time, the pause time will not be used in normal gate operation.)

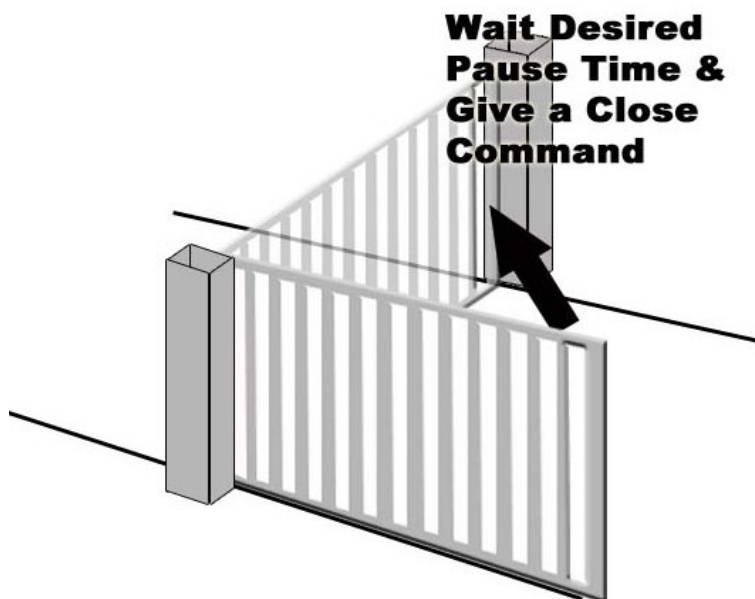

Dual gates are programmed simultaneously. Move both of the leafs to the same starting position and both leave will move together through the same programming sequence.

Photocell & Safety Device Guide

Before connecting the photocells (or other devices) we advise you to select the type of operation according to the movement zone to be protected.

Opening Safety Devices: They operate only during the gate opening movement and, therefore, they are suitable for protecting the zone between the opening leaves and fixed obstacles (walls, etc.) against the risk of impact and crushing.

Closing Safety Devices: They operate only during the gate closing movement and, therefore, are suitable for protecting the closing zone against the risk of impact.

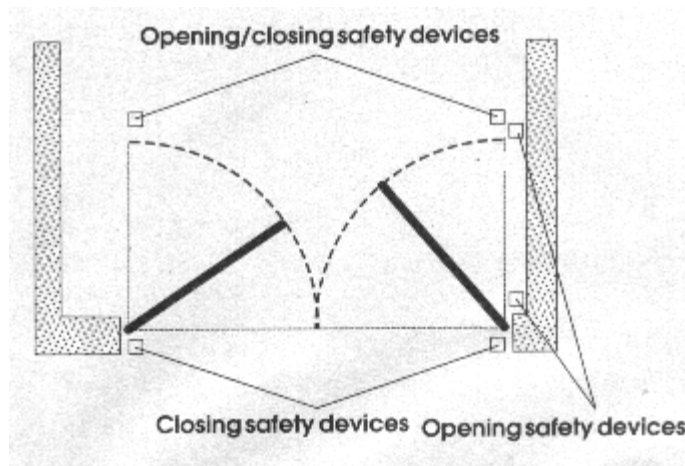

Opening/Closing Safety Devices: they operate during the gate opening and closing movements and, therefore, they are suitable for protecting the opening and closing zones against the risk of impact.

If one or more devices have the same function (opening or closing) they must be connected to each other in series. Normally Closed contacts on the accessories panel must be used.

Installing and Setting Transmitters and Receivers

Installing the Receiver

- 1) Locate the 5 Silver Pins in the lower right hand corner of the Estate Swing board.
- 2) Locate the **white** connector on the receiver.
- 3) Push the **white** connector from the receiver on the 5 pins on your FAAC board with the dip switches of the receiver board facing away from the Estate Swing board.

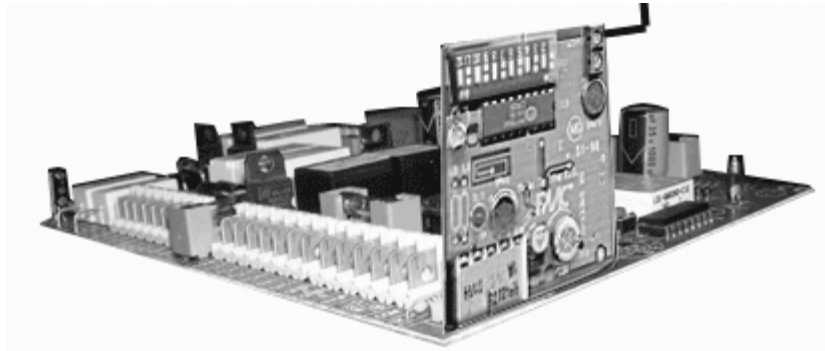

Setting the Dip Switches

- 1) Set the dip switches 1-9 on the receiver by switching them in the up or down position.
Record this dip switch combination
- 2) Slide off the battery cover of the transmitter (*located at the bottom front cover*)
- 3) Set the dip switches in the transmitter to the same settings as the dip switches on the receiver.
- 4) Repeat this for all of the transmitters.



Dip switches are located under the battery lid.

Troubleshooting

If the gate opener will not move.

Be sure you have gone through programming. Without programming no power is ever sent to the operator arms.

Check wiring connections.

Check to be sure jumpers are in place between STOP, FSW OP, FSW CL to COM on terminal block CN4.

If not using limit switches, be sure jumpers are in place between FCC1, FCA1, FCC2, FCA2 to COMF on terminal block CN3.

Be sure the arms are locked out of manual operation.

Check all fuses, the fuses protect as follows but all are required for the arms to move:

F1: 10A – Power Supply, 24VAC

F2: 630 mA – Power supply to accessories and battery charger

F3: 630 mA – Flashing lamp output

F4: 3.15A – Electric Lock Output

If the gate opener move a few inches or feet and stops or reverses directions.

Check dip switches to the left of the LED display. It should be 1:OFF, 2:OFF, 3:ON, 4:On. If the dip switches are wrong, you **must** turn all power off before changing the dipswitches and then turn power back on for the settings to take effect.

Increase the force setting to the highest force. The force setting is the A parameter, move the A parameter to 4. If the gate moves fully after doing so you may then work your way down force settings to the lowest force setting that the gate still moves correctly under.

Check the setback. The setback of the operator is important to correct operation due to leverage the arm will have on the gate.

If using limit switches, check limit switch placement and wiring. You can tell if a limit switch has been triggered by watching to see if one of the lights above FCC1, FCA1, FCC2, FCA2 go unlit. Whichever limit light is unlit is engaged.

Continued on next page.

If fuse the F2 fuse blows or continues to blow.

Check all wiring to both the backup batteries and to all accessories run off of the 24+,- terminals on terminal block CN1. Check for the following:

- The batteries are run in **series** not parallel. If they are run in parallel the batteries will become overcharged and be destroyed, which will then create a short and continually blow the F2 fuse.
- The accessories going into 24V+, - must have the correct polarity.
- The accessories going into 24V+, - cannot exceed a combined power draw of more than 500 mA.

Check the battery voltage, if the battery voltage is very low you may have dead cells in the battery causing an overdraw of current and blowing the fuse. Replace the batteries.

If the gate reaches it's closed position during the learning process but does not re-open.

Touch the reset pins (RST) to reset the system. Change the i parameter to 0. Restart the learning process.

Contact Estate Swing for alternate power supply to correct a lack of correct voltage and/or amperage outputs under load.

The gate does not reach the desired stop points.

If not using limit switches:

- Be sure the arm can go full expected range. Manually release the arms and move the gates by hand to possible range. Do not let the arm reach its physical limitations before the stops during normal operation.
- If arms can't extend full expected range, check the setback. 6 ½ x 6-½ inch setback is the correct setback for a 110-degree opening.
- If the opener arm has the physical possibility of opening yet still stops, increase the force setting to the highest force. The force setting is the A parameter, move the A parameter to 4. If the gate moves fully after doing so you may then work your way down force settings to the lowest force setting that the gate still moves correctly under. The ending positions are where the most stress is put on the arm and the leverage is the lowest.

If using limit switches:

- Check limit switch placement and wiring. You can tell if a limit switch has been triggered by watching to see if one of the lights above FCC1, FCA1, FCC2, FCA2 go unlit. Which ever limit light is unlit is engaged.
- If limit switches are to the furthest points possible on both the closed and open positions, check the setback. 6 ½ x 6-½ inch setback is the correct setback for a 110-degree opening
- If the opener arm has the physical possibility of opening yet still stops, increase the force setting to the highest force. The force setting is the A parameter, move the A parameter to 4. If the gate moves fully after doing so you may then work your way down force settings to the lowest force setting that the gate still moves correctly under. The ending positions are where the most stress is put on the arm and the leverage is the lowest.



If you call in for technical support or warranty support: before any control board or motor will be permitted to be sent in for testing or warranty you will be required to e-mail digital photos to the technician.

This is done in your best interest to save unnecessary shipping expenses and time lost. Many times we can come up with solutions to issues by seeing pictures that relay information that is impossible to relay through a phone conversation.

Below is an example of a control board picture that we will be looking for:

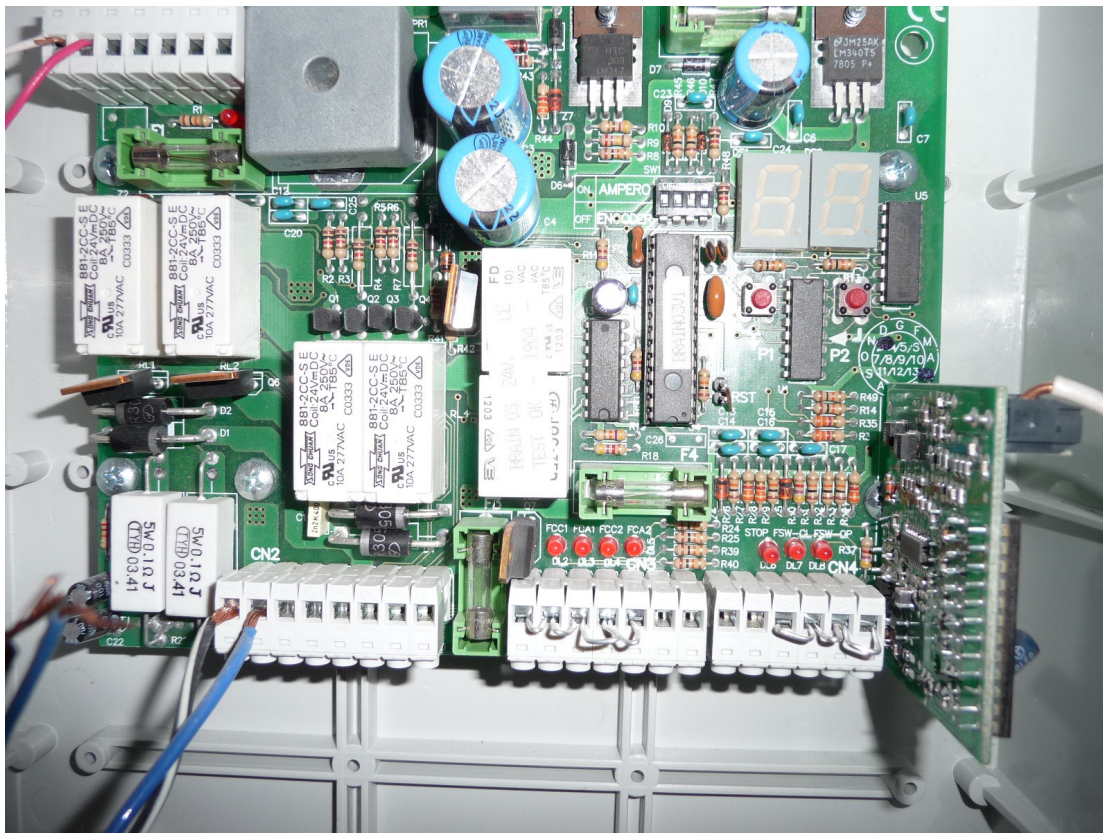

Installing Accessories

Accessory manuals for most make and model accessories can be found on the web at:

www.EstateSwing.com/accessories

The accessory manuals you have or find at the above address may be written to coincide with that manufacturer's model of gate opener. To determine correct terminals on your Estate Swing operator, use the accessory terminal section of your Estate Swing manual. The following are some common terms and abbreviations found in manuals:

Normally Open – abbr. N/O – Indicates a circuit that is left open during normal operation of the gate operator. When a device closes this circuit it signals the operator to perform a function. This circuit is the main circuit for entry devices. (i.e. keypads, exit wands, push buttons, etc.)

Normally Closed – abbr. N/C – Indicates that in order for the gate opener to be active this circuit must be closed. When a device opens this circuit it stops the motion of the gate operator. This circuit is the main circuit for safety devices. (i.e. photo eyes, safety loops, etc.)

Common – abbr. COM – This is the matching terminal for both Normally Open and Normally Closed circuits to be connected to. Accessory wiring that begins in a N/O or N/C terminal must have a wire that ends in a Common terminal.

Ground – abbr. GND or GRD – Ground is sometimes also known as negative. Common terminals are the same as Ground terminals. Ground can also be the negative spade of the battery if it is being used in association with positive voltage.

If a device has both a N/O and a N/C wire, both are never used at the same time. Some devices can be used as either an opening device or a safety device (i.e. gate crafters exit wand, NIR photo eye, etc.) If being used as an opening device use the N/O and if being used as a safety device use the N/C terminals.