

USER DRIVEN MANUAL*

Any feedback, changes, or advice we are glad to hear it. Please contact us at support@estateswing.com

—WARNING—

Read all instructions before beginning installation or use of this gate opener.
This operator exerts a high level of force.
Exercise caution at all times and stay clear of the system during operation.

Estate SWING

ESTATESWING.COM

LOOK INSIDE



For QR Codes you can scan with your smartphone to view supplementary videos

E-S 300 / 302 Classic Series

INSTRUCTION MANUAL

**Estate Swing's unique user driven manuals are constantly updated by installers and homeowners like yourself. We improve by hearing and applying your feedback.*

Estate Swing Summary of Functions

The Estate Swing is only to be used for vehicular swing gates in a Class I setting.

Class I: A vehicular gate opener (or system) intended for use in a home of one-to-four single family dwelling, or a garage or parking area associated therewith.

The Estate Swing automated system was designed and built for controlling vehicle access. Do not use for any other purpose.

The external automation with an electro-mechanical non-reversing linear arm automates residential swing-leaf gates with leaves of up to 12' in length. It consists of an irreversible electro-mechanical operator with built in opening and closing limits and utilizes a worm screw system. The irreversible system ensures the gate is mechanical locked when the motor is not operating. A lock still needs to be installed if security or high winds are a concern. A manual release makes it possible to move the gate in the event of a power-cut or fault.

For Your Assistance

Keep this manual safely stored after installation

Serial Number _____

Date of Purchase _____

Place of Purchase _____

Have this information on hand while handling all service and warranty issues.

Table of Contents

The table of contents are listed to assist you locating a desired section. We do however strongly suggest studying every page of the instruction manual before attempting installation.

Section 1: Review of Specifications, Warnings, and Tools

Specifications of the Estate Swing and Components	1.1
Parts List	1.2
System Overview & Preliminary Checks	1.3
Tools Needed for Installation	1.4

Section 2: Installation of Mounting Brackets

Manual Operation, Restoring Automation	2.1
Pull to Open Illustration	2.2
IMPORTANT: Determining Setback—Pull to Open	2.3
Installation of Operator—Pull to Open	2.4-5
Push to Open Illustration	2.6
IMPORTANT: Determining Setback—Push to Open	2.7
Installation of Operator—Push to Open	2.8-9

Section 3: Gate Operator Mounting, Wiring Motors and Power

Mounting Gate Operator(s)	3.1
Check Usage of Stroke	3.2
Control Box & Running Wires	3.3
Easy Wiring Under Driveway	3.4
Removing Terminal Strips for Wiring	3.5
Wiring the Operator Arms(s) (Pull & Push to Open)	3.6-7
Temporary Safety Jumpers & Dip Switch Settings	3.8
Power	3.9

Section 4: Start Up and Operation

Find Limit Positions	4.1
First Run	4.2
Determine Run Time	4.3
Operating Parameters Customization	4.4

Section 5: Maintenance, Troubleshooting, and Accessories

Maintenance	5.1
Troubleshooting	5.2-.4
Control Board Overview	5.5-.8
Accessories	5.9

Section 1:

Review of Specifications, Warnings, and Tools

Specifications

MODEL	Estate Swing E-S300/302
Power Supply	24V AC, 50VA to 120VA
Backup Battery Voltage	24V DC
Current (A)	3
Travel (in.)	12
Cycles per hour	50% Duty Cycle / Aprox. 35
Operating Ambient Temp	-20 to 130 F
Protection class	IP44
Gate leaf max length (ft.)	Up to 12
Gate leaf max weight (lbs.)	Up to 600
Operator Type	Screw Drive
Operator Weight	14 lbs

Gate Weight/Length Ratio	6'	8'	10'	12'
100lbs	X	X	X	X
200lbs	X	X	X	X
300lbs	X	X	X	X
400lbs	X	X	X	
500lbs	X	X		
600lbs	X			

The above chart represents the maximum weight and length combinations that this gate opener can handle. The lengths and weights are either for a single gate or for a single leaf of a dual gate.

Estate Swing Parts List



Master or Single Operator

- A. Control Box with Control Board
- B. Operator Arm with 42" of Wire
- C. Key
- D. Connector Pins and C Rings
- E. Transformer
- F. Post Mounting Brackets
- G. Gate Mounting Bracket

Not Shown:

- Mounting Hardware
 - 1 - 3/8"x1 3/8" Hex bolts, washer, nut
 - 1 - 5/16"x 1 3/8" Hex bolt, washer, nut
 - 2 - 3/8"x 2" Carriage bolt, washers, nut
 - 1 - 1/4" x 2" Hex bolt, washers, nut

Slave Operator (if applicable)

- A. N/A
- B. Operator Arm with 42" of Wire
- C. Key
- D. Connector Pins and C Rings
- E. N/A
- F. Post Mounting Brackets
- G. Gate Mounting Bracket

Not Shown:

- Additional Wire
- Mounting Hardware
 - 1 - 3/8"x1 3/8" Hex bolts, washer, nut
 - 1 - 5/16"x 1 3/8" Hex bolt, washer, nut
 - 2 - 3/8"x 2" Carriage bolt, washers, nut
 - 1 - 1/4" x 2" Hex bolt, washers, nut

Standard System Overview and Safety Zones

The system displayed below is a recommended standard system. Other approved accessories can be installed. Photo sensors and a flashing light indicating gate movement is recommended for safety purposes.

1,2 Estate Swing Operator • 3 Photocells (not included) • 4 Control board • 5 N/A
6 Push button opening device (not included) • 7 Receiver extension (not included) • 8
24Vdc flashing lamp (not included) • 9 Positive stop (not included) • 10 AC transformer

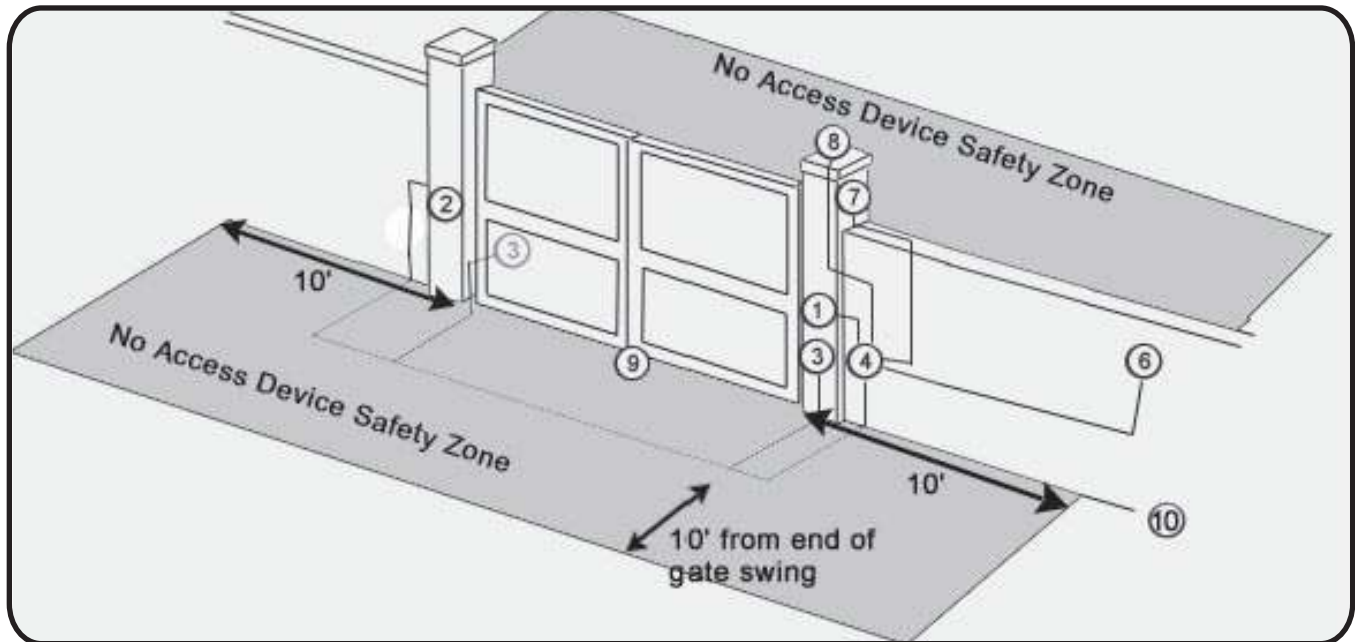

Notes: 1) When laying electrical cables, use appropriate rigid and/or flexible tube
2) Do not run any wires in the same conduit as 110 AC power that may be in the area. This will cause danger of electrocution.

IMPORTANT: Preliminary Checks

To ensure safety and an efficiently operating automated system, make sure the following conditions are observed.

- The gate and post must be suitable for being automated. Check that the structure is sufficiently strong and rigid, and its dimensions and weights conform to those indicated on page 1.
- Make sure the gates move smoothly without any irregular friction during entire travel.
- Make sure the hinges are in good condition. Ball bearing hinges are necessary for gates weighing over 200 lbs. or over 10' in length.
- Make sure the gate is plumb and level.
- The gate post must be secured in the ground with concrete. This will prevent alteration of alignments and leveling during installation and during cycles.

Tools Needed for Installation



- Power Drill
- Crescent Wrench
- Flat Head Screwdriver
- Hacksaw/Sawzall
- Phillips Head Screwdriver
- Small Flathead Screwdriver

- C-Ring Pliers
- Tape Measure
- Level
- Wire Strippers
- C-clamps
- 3/8", 1/4", 5/16" Drill Bits

Other items may be needed prior to commencing installation. **BOLDED** items are necessary to all applications.

- Positive post, bracket or door stop. Although the Estate Swing 300 features built in limit switches it is highly recommended to have positive stops.
- **16 gauge, 2 conductor stranded direct burial low voltage wire** will be required to run power to your operator. Length is determined by distance between transformer power supply and the control box.
- **4 - 3/8" Carriage Bolts** will be needed to connect the **2 "L" shaped brackets** to the post. Length will be determined by the size of your posts.
- A metal support bracket may be needed to achieve the appropriate desired setback. The metal support bracket will be bolted or welded to your post to give a larger amount of space to mount the provided mounting bracket.
- A voltage meter and digital camera may be necessary to run diagnostic checks.
- If your transformer is going to be plugged into an outdoor outlet you will need to weatherproof that outlet and transformer. **Electrical boxes or plug covers** can be obtained from a local hardware store to accommodate both the plug and transformer.
- Hardware to attach the control box to a post or fence.



Protect all ingoing and outgoing wires with a surge suppressor.
Consult your local dealer for more information.

Section 2:

Installation of Mounting Brackets

Manual Operation



- 1) Lift lock cover cap off.
- 2) Insert and turn provided key.
- 3) The operator can now be pull or push open.
- 4) Replace lock cover to protect lock from water and debris.

To exit manual mode, repeat the above steps.

Restoring Automation

To maintain the proper performance of your emergency release - please perform the following service for your motor once per year.

1. Remove the emergency release cap
2. Spray some WD-40 or other spray lubricant into the release lock.
3. Allow the lubricant to soak in.
4. Apply a liberal dab of petroleum based jelly or wheel bearing grease to coat the release lock.
5. Put the cap securely back in place.



IMPORTANT: Pull To Open Operation

This means the gate operator is mounted on the inside of the property and pulls your gate in towards the property. **If you are going to use push to open operation "X" out the next 3 pages and use the push to open section instructions.**

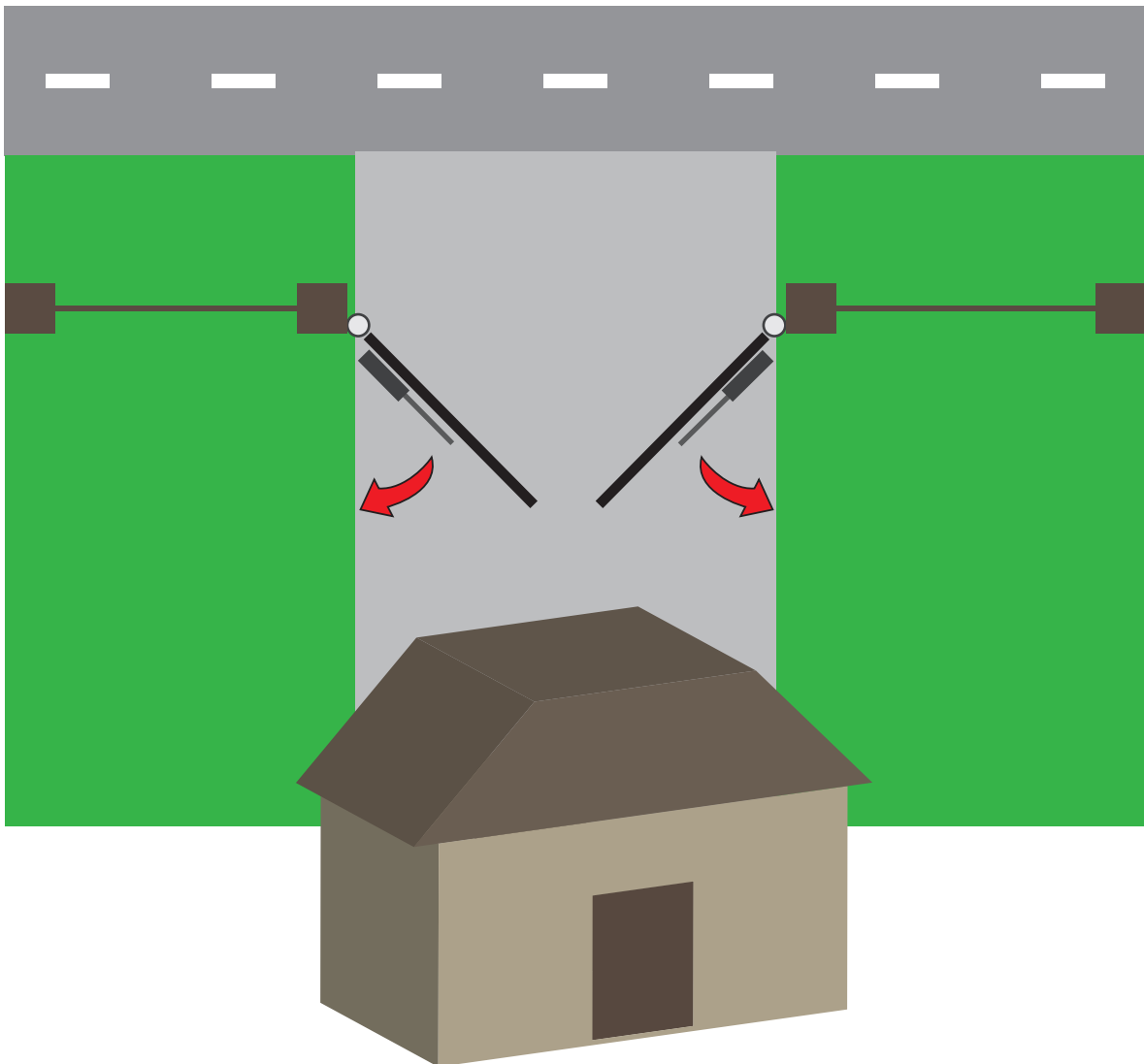

IMPORTANT: Determining Correct Setback

Below are 3 common examples of setback mountings & common mistakes made. These are not the only options for mounting.



*Rear pivot point indicated by gray tip. It may face up or down depending on the side of the gate.

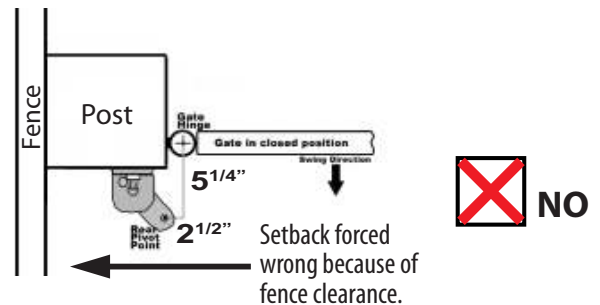
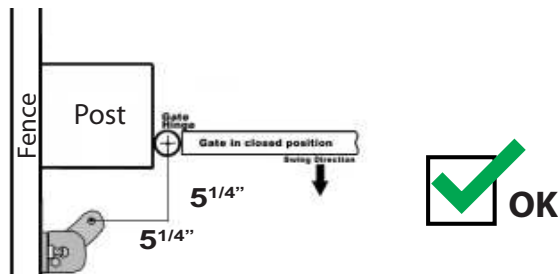
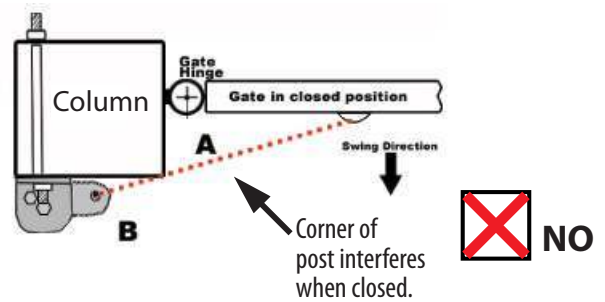
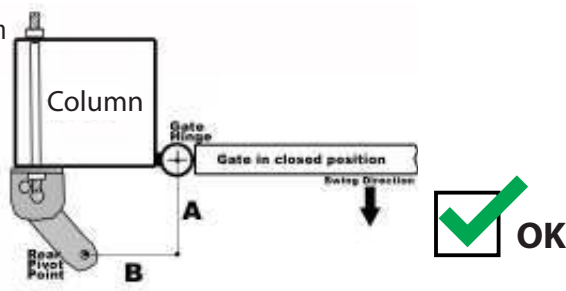
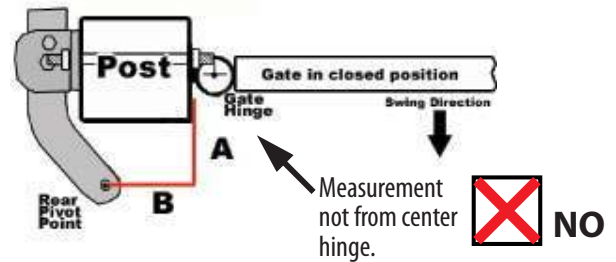
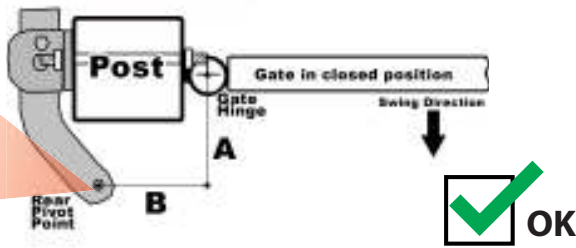

There are 3 factors to keep in mind when finding the setback mounting:

- 1) The measurements must be correct from the center of the hinge of the gate to the center of the hole on the mounting bracket.
- 2) There must be clearance for your opener to attach to your gate in the closed position.
- 3) The brackets do not move or pivot after mounting, if you can achieve the setback and clearance then bracket position is inconsequential.

It is best to C-Clamp brackets on and test arm movement clearance before permanently attaching them.

Variations to the ideal setback can be made, so long as the total is less than the combined measurements for the desired opening arc and the motor body is more than 2 inches away from the gate in both the open and closed position. (setback variations significantly reduces the length and weight capacity of the operator)

Use one of the rows below:

A	B	Sum	<i>a</i>
4 3/4"	5 1/4"	10	110°
5 1/4"	5 1/4"	10 1/2	100°
5 1/2"	5 1/2"	11	90°

To determine the position of the gate mounting bracket (above is for the post mounting bracket) refer to step 13 in the section "Installation of operator"

Installation of Operator—Pull-to-Open

1. Locate the set back and boomerang bracket templates found in the box to determine the proper setback.

2. Find the proper setback for your operator (from previous page). Hold the lower “L” shaped bracket along with the boomerang bracket template against the post near the hinge. [See Fig. 1]

Mark how much of the boomerang bracket you will trim off on the template. **The hole on the end of the boomerang bracket should be in the setback position.**

3. Trim boomerang bracket template, then double check setback positioning.

Using the template, mark the boomerang bracket for cutting. [See Fig. 2]

4. Cut off the excess length (if any) of the boomerang bracket using a sawzall or hacksaw.



CAUTION: Observe all safety precautions recommended by manufacturer of the cutting tool.

5. Using a measuring tape, measure vertically to find the center of the horizontal mount on the gate, then place a mark. [See Fig. 3]

6. Utilizing a level, measure from the center of the horizontal mount of the gate to the post to the get bracket position. Place a mark on the post at this point. [See Fig. 4]

7. Temporarily position the gate bracket on the post. Align the top of the gate bracket with the marking created in the previous step. Make an additional mark at the bottom of the gate bracket. This will mark the position for the top of the lower “L” shaped bracket. [See Fig. 5]



Need more help?

Scan this code with your smartphone to view a supplementary video. Or go to:
http://youtu.be/H_ja7spgJAM

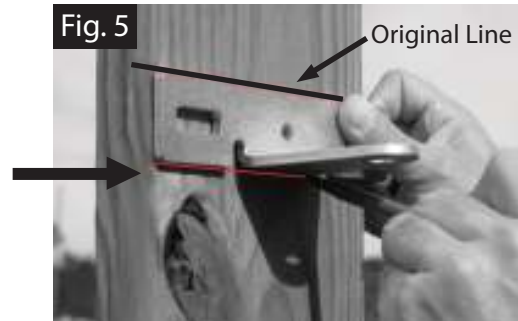
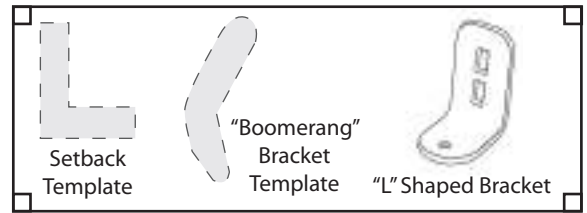

Installation of Operator—Pull-to-Open

BEFORE PERMANENTLY ATTACHING ANY BRACKETS, BE SURE TO TEST ARM MOTION AND CLEARANCE.

8. Place the lower “L” shaped bracket so the top of the bracket is aligned with the bottom marking on the post. Mark then drill and attach the bracket using 3/8” carriage bolts. [See Fig. 6]

Check “L” shaped bracket for levelness before putting in the second bolt.

9. Place the upper “L” shaped bracket and the boomerang bracket on the lower “L” shaped bracket. **Position the brackets in the setback that is being used.**

10. With the 3 brackets clamped together, mark then drill the upper “L” shaped bracket in place and attach it using 3/8” carriage bolts. [See Fig. 7]

11. Drill through the center hole of the “L” shaped set to penetrate the boomerang bracket. **Double check the setback on the boomerang bracket.**

12. Drill the set hole through all 3 brackets using a 5/16” drill bit in an area behind the first hole. Secure the hole with a 5/16” bolt and the provided nuts and lock washers. [See Fig. 8]

13. **WITH THE GATE IN THE CLOSED POSITION** measure 38” from the center of the hole on the boomerang bracket to the center of the hole on the gate bracket - this should be the position of the gate bracket on the closed gate. [See Fig. 9]

14. Additionally measure and mark the gate mounting bracket so that it is vertically centered on the horizontal bar.

15. To ensure that the gate mounting bracket is leveled, secure one side of the bracket, check for levelness, and secure the other side with provided carriage bolts, nuts, and washers. [See Fig. 10]

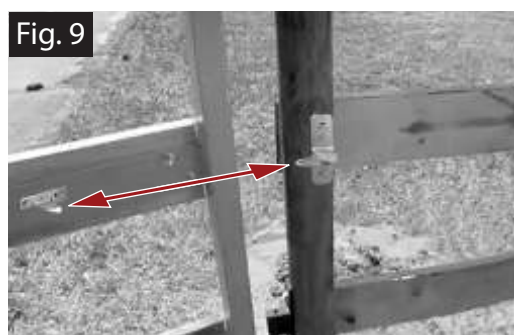

IMPORTANT: Push To Open Operation

This operation is commonly used if your driveway slopes up after the gate, preventing it from swinging in. This means the gate operator is mounted on the inside of the property and pushes your gate out away from the property.

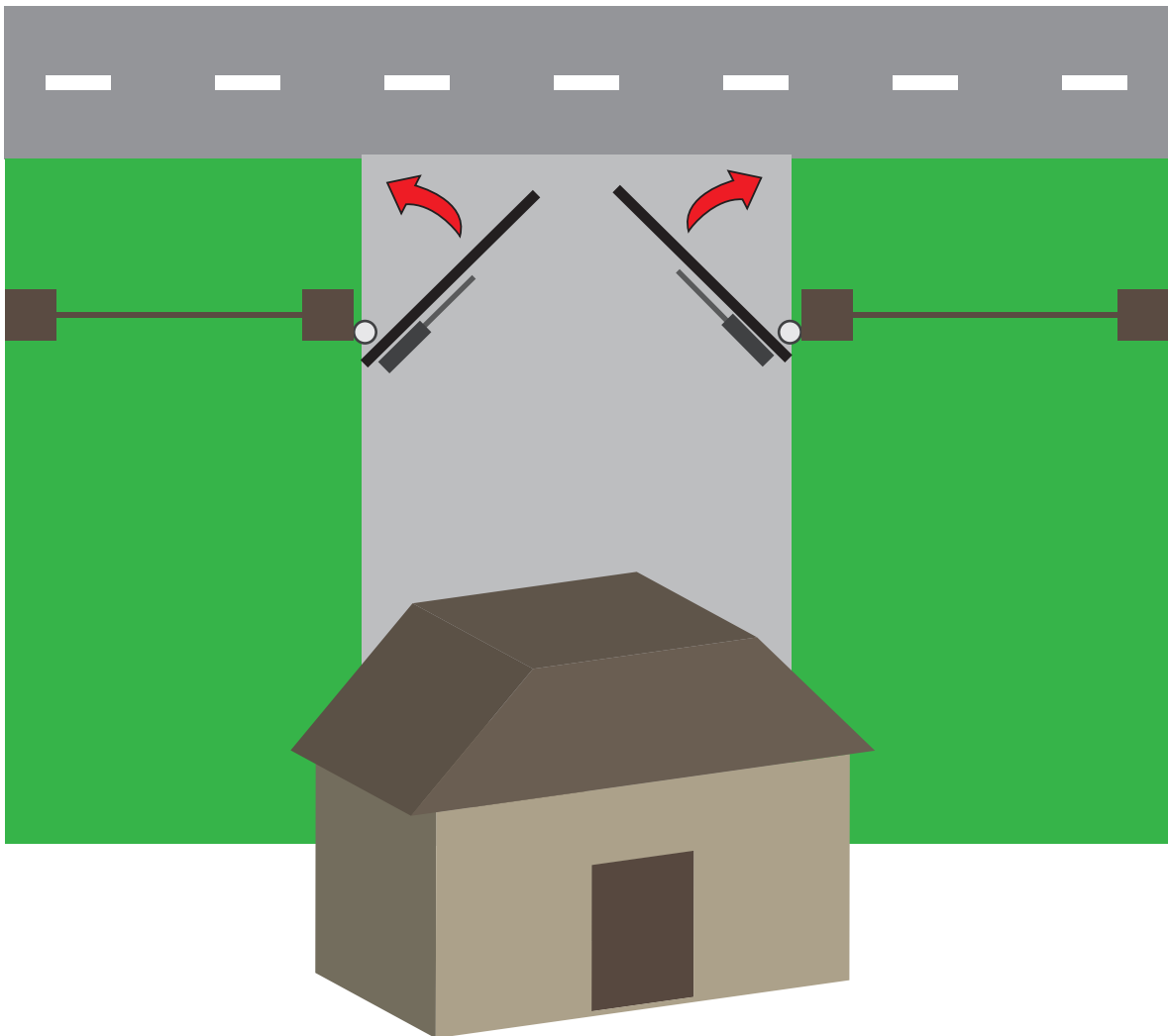

IMPORTANT: Determining Correct Setback

Below are 2 common examples of setback mountings & common mistakes made. These are not the only options for mounting.

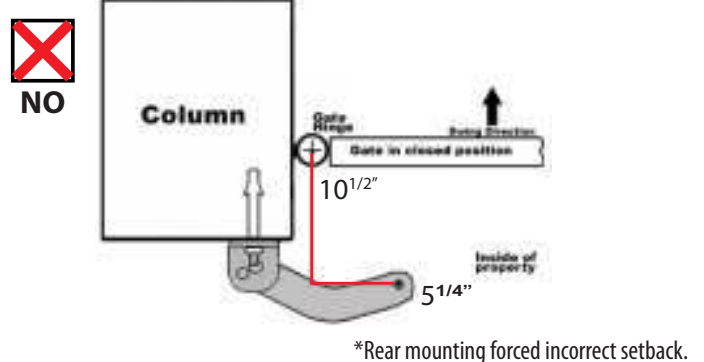
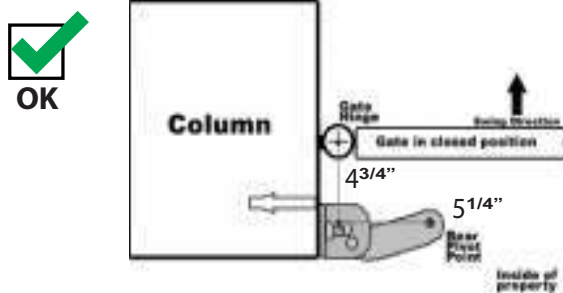
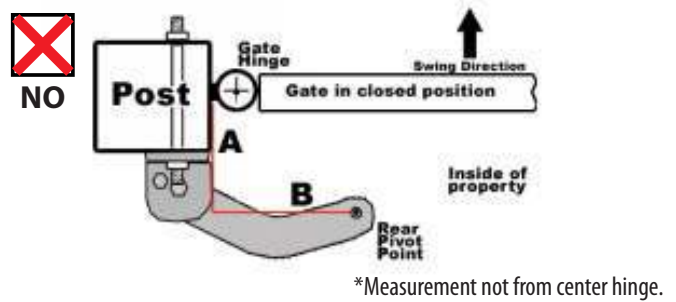
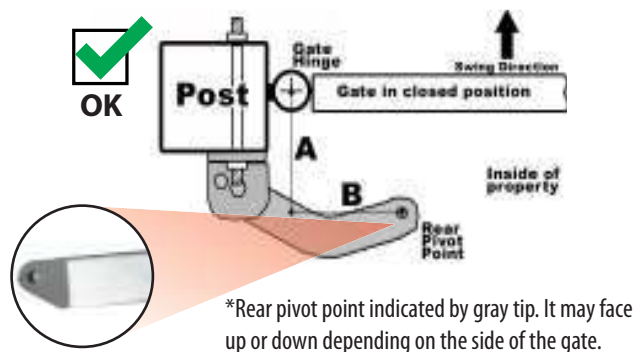

There are 3 factors to keep in mind when finding the setback mounting:

- 1) The measurements must be correct from the center of the hinge of the gate to the center of the hole on the mounting bracket.
- 2) There must be clearance for you opener to attach to your gate in the open position.
- 3) The brackets do not move or pivot after mounting, if you can achieve the setback and clearance then bracket position is inconsequential.

It is best to C-Clamp brackets on and test arm movement clearance before permanently attaching them.

To determine the position of the gate mounting bracket (above is for the post mounting bracket) refer to step 13 in the section "Installation of operator - PTO"

Use one of the rows below:

A	B	Sum	α
4 ³ / ₄ "	5 ¹ / ₄ "	10	110°
5 ¹ / ₄ "	5 ¹ / ₄ "	10 1/2	100°
5 ¹ / ₂ "	5 ¹ / ₂ "	11	90°

Variations to the ideal setback can be made, so long as the total is less than the combined measurements for the desired opening arc and the motor body is more than 2 inches away from the gate in both the open and closed position. (variations significantly reduces the length and weight capacity of the operator)

Installation of Operator—Push-to-Open

1. Locate the set back and the boomerang bracket templates found in the box to determine the proper setback.

2. Find the proper setback for your operator (from previous page). Hold the lower “L” shaped bracket along with the boomerang bracket template against the post near the hinge. [See Fig. 1]

Mark how much of the boomerang bracket you will trim off on the template. **The hole on the end of the boomerang bracket should be in the setback position.**

3. Trim boomerang bracket template, then double check setback positioning.

Using the template, mark the boomerang bracket for cutting. [See Fig. 2]

4. Cut off the excess length (if any) of the boomerang bracket using a sawzall or hacksaw.



CAUTION: Observe all safety precautions recommended by manufacturer of the cutting tool.

5. Using a measuring tape, measure vertically to find the center of the horizontal mount on the gate, then place a mark. [See Fig. 3]

6. Utilizing a level, measure from the center of the horizontal mount of the gate to the post to get bracket position. Place a mark on the post at this point. [See Fig. 4]

7. Temporarily position the gate bracket on the post. Align the top of the gate bracket with the marking created in the previous step. Make an additional mark at the bottom of the gate bracket. This will mark the position for the top of the lower “L” shaped bracket. [See Fig. 5]

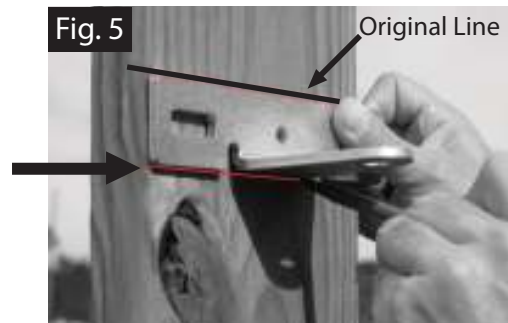
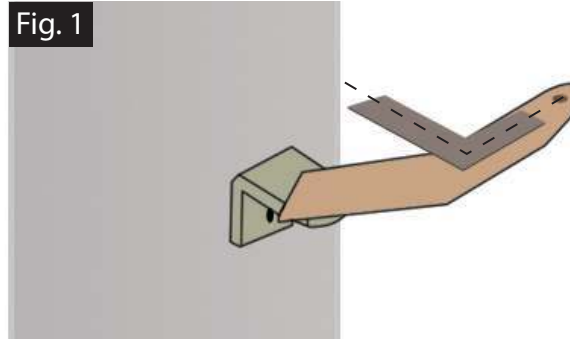
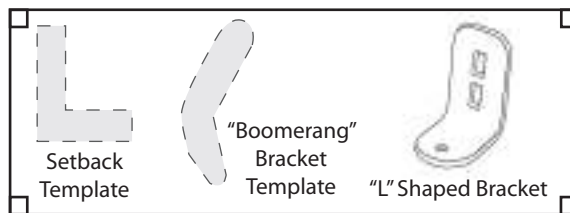

Need more help?

Scan this code with your smartphone to view a supplementary video. Or go to:
http://youtu.be/H_ja7spgJAM



Installation of Operator—Push-to-Open

BEFORE PERMANENTLY ATTACHING ANY BRACKETS, BE SURE TO TEST ARM MOTION AND CLEARANCE.

8. Place the lower “L” shaped bracket so the top of the bracket is aligned with the bottom marking on the post. Mark then drill and attach the bracket using 3/8” carriage bolts. [See Fig. 6]

Check “L” shaped bracket for levelness before putting in the second bolt.

9. Place the upper “L” shaped bracket and the boomerang bracket on the lower “L” shaped bracket. **Position the brackets in the setback that is being used.**

10. With the 3 brackets clamped together, mark then drill the upper “L” shaped bracket in place and attach it using 3/8” carriage bolts. [See Fig. 7]

11. Drill through the center hole of the “L” shaped set to penetrate the boomerang bracket. **Double check the setback on the boomerang bracket.**

12. Drill the set hole through all 3 brackets using a 5/16” drill bit in an area behind the first hole. Secure the hole with a 5/16” bolt and the provided nuts and lock washers. [See Fig. 8]

13. **WITH THE GATE IN THE OPEN POSITION** measure 38” from the center of the hole on the boomerang bracket to the center of the hole on the gate bracket - this should be the position of the gate bracket on the open gate. [See Fig. 9]

14. Additionally measure and mark the gate mounting bracket so that it is vertically centered on the horizontal bar.

15. To ensure that the gate mounting bracket is leveled, secure one side of the bracket, check for levelness, and secure the other side with provided carriage bolts, nuts, and washers. [See Fig. 10]

Fig. 6



Fig. 7



Fig. 8



Fig. 9

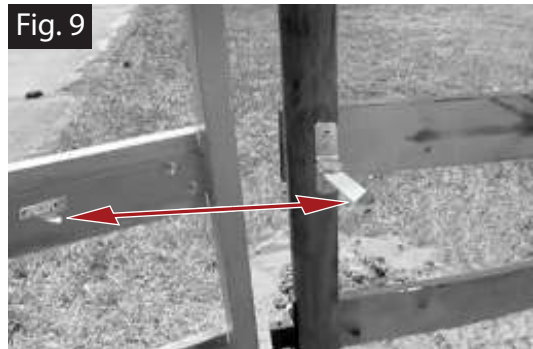

Fig. 10



Section 3:

Gate Operator Mounting, Wiring Motors & Power

Mounting Gate Operator(s)

1) Slide the rear of the gate operator into the boomerang bracket. Next, secure the operator onto the bracket with a connector pin.



2) Utilize the C-clip pliers in order to attach a C-clip on the bottom side of the connector pin.

3) Move the gate towards the operator arm and slide the front of the operator onto the gate bracket.



4) Secure the front side of the gate operator with a connector pin, followed by a C-clip.

Check Usage of Stroke

1) Manually unlock the gate operator.



2) Physically swing the gate operator so that it is almost fully extended in the closed position, but not bottoming out.



3) Swing the arm back to its open position so that it is almost fully retracted, but not bottoming out.

For the Push to Open Operation follow the directions shown above, except reverse the position of the gate.

If not using all of the stroke length, please re-check setback. Not using the full stroke length of the gate operator, the gate will have limited leverage.

Control Box & Running Wires

Control Box Mounting:

- The control box can be mounted on a post or fence line.
- If you have a dual operator set up, make sure it is located within 45' of the slave motor.
- Allow at least 3 feet of clearance off the ground.

Wiring:

- Cut to fit the proper water tight connector ring for your wire(s).
- Fill in any visible gaps with caulk.



Dual Operation Junction Box:

You will need the following items for this installation:

- Second Junction Box
- Screws
- PVC Conduit

- 1) Set aside the junction box cover and screws.
- 2) Drill two holes in the bottom of the junction box large enough to fit the cables.
- 3) Mount the junction box within 5 feet of slave operator.

The junction box can be mounted on a post or a fence line. Allow at least 3 feet of clearance off the ground.

- 4) Insert operator cable and extension cable into the holes in the bottom of the junction box, and seal with caulk.

**You may also use a watertight connector and connector nut to secure the cables. Found at your local hardware store.*

- 6) Insert wires from extension cable and operator cable into the terminal block connector as seen to the right.
- 7) The terminal block may be kept loose or fastened inside of the junction box.
- 8) Install and secure cover.

See next page for instructions on running wire under the driveway.

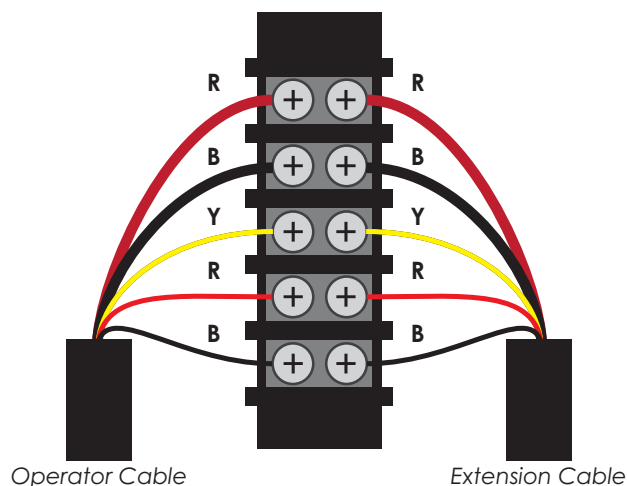
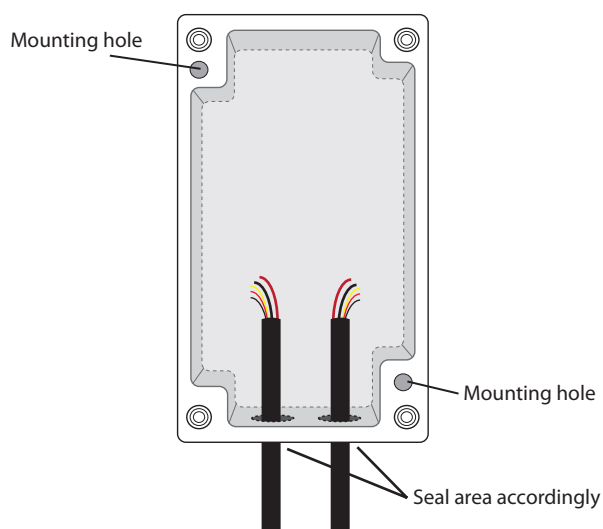

TIP: If junction box is located in a high moisture area, apply petroleum jelly on to the terminal block to protect from moisture.

Easy Wiring Under Driveway

This portion of the manual will explain how to create an easy conduit for the wires for **dual gates**.

This is what you would need to get started:

- Narrow shovel.
- $\frac{3}{4}$ ' water pipe no more than 5' in length (you would need a total number of pipes that would equal your driveway width plus 1').
- $\frac{3}{4}$ ' electric rigid pipe couplings (one for each joint in the water pipe).
- 1 $\frac{3}{4}$ ' "Tee".
- 1 $\frac{3}{4}$ ' Plug.
- 1 $\frac{3}{4}$ ' male galvanized pipe X female hose fitting (usually in Brass).
- Large hammer.



All the above items could be found in a local home supply store.

Dig a trench perpendicular to the driveway approximately 6 to 8 inches deep and 6' long

Hook up a typical garden hose assembled to the first length of pipe as shown

Turn on water and push the pipe under the driveway, matching the pitch of the driveway. If you hit a rock use the hammer to force the pipe past the rock.

Attach additional pieces of pipe to the initial length by removing the tee and using the coupling to add the additional length of pipe, reassemble the tee and repeat the above steps until only 6 inches of pipe is sticking out from under the driveway. On the opposite side of the driveway look for a wet spot or water bubbling up, dig to find the end of the pipe.

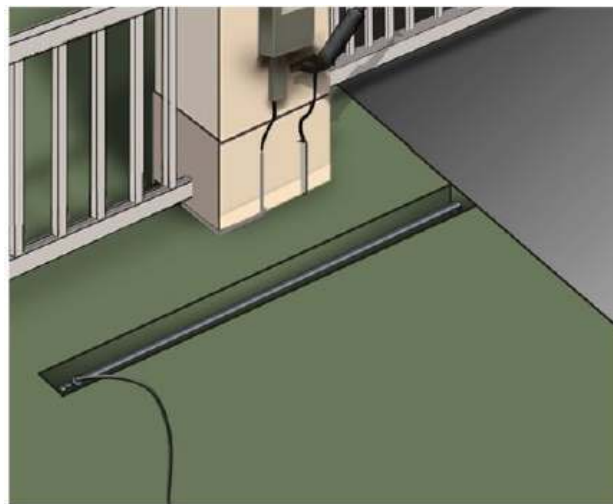

This process is good for driveways up to 24' in width.

For Your Convenience

The green terminal strips on the control board are easily removed for wiring. Simply pull straight out on the terminal strip to remove it from the board. It will slide right off. Slide it back on when you are finished with your wiring connections.

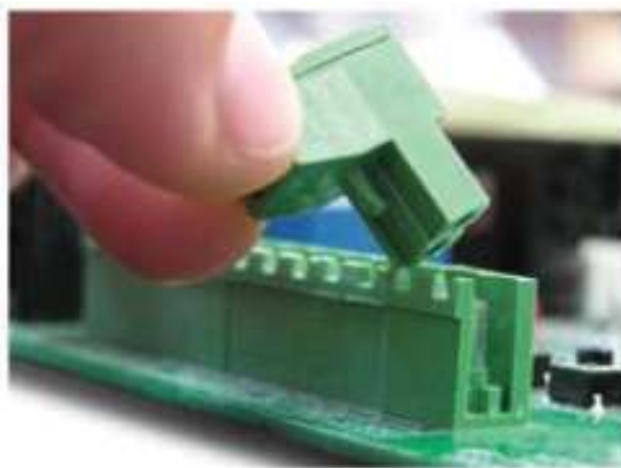

Be sure you are placing your wires in the terminal block correctly.

Take the terminal block off of the control board to insert wires. Hold with screw terminals facing upward.

Turn the screw counter-clockwise to open the terminal and clockwise to close the terminal.

The terminals come closed. Be sure not to mistake this for open and insert the wires below the terminal clamp. This will lack the conductivity to complete the circuit.



Wiring the Operator Arm(s)

For a dual gate use the provided wire to connect the secondary motor to the control board.

Pull to Open
(Opening in towards property)

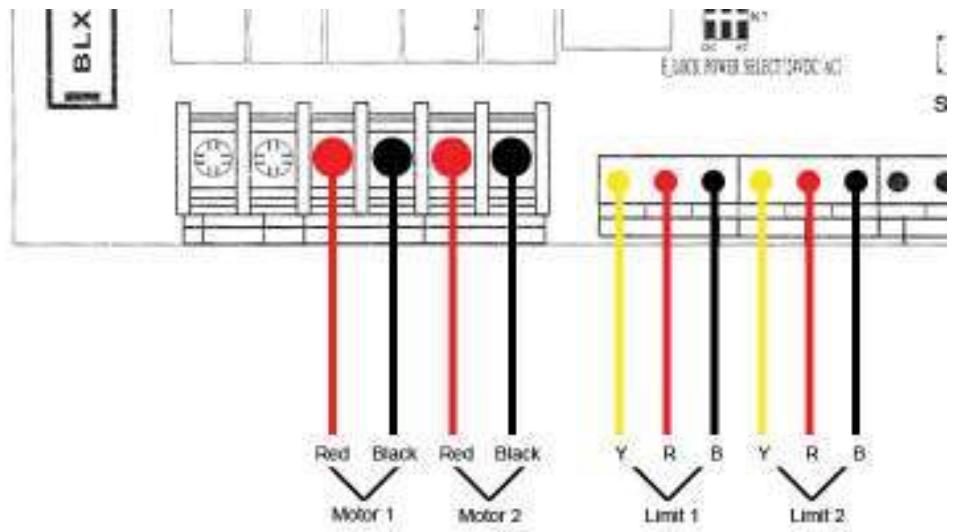

It is important to choose the correct operation type

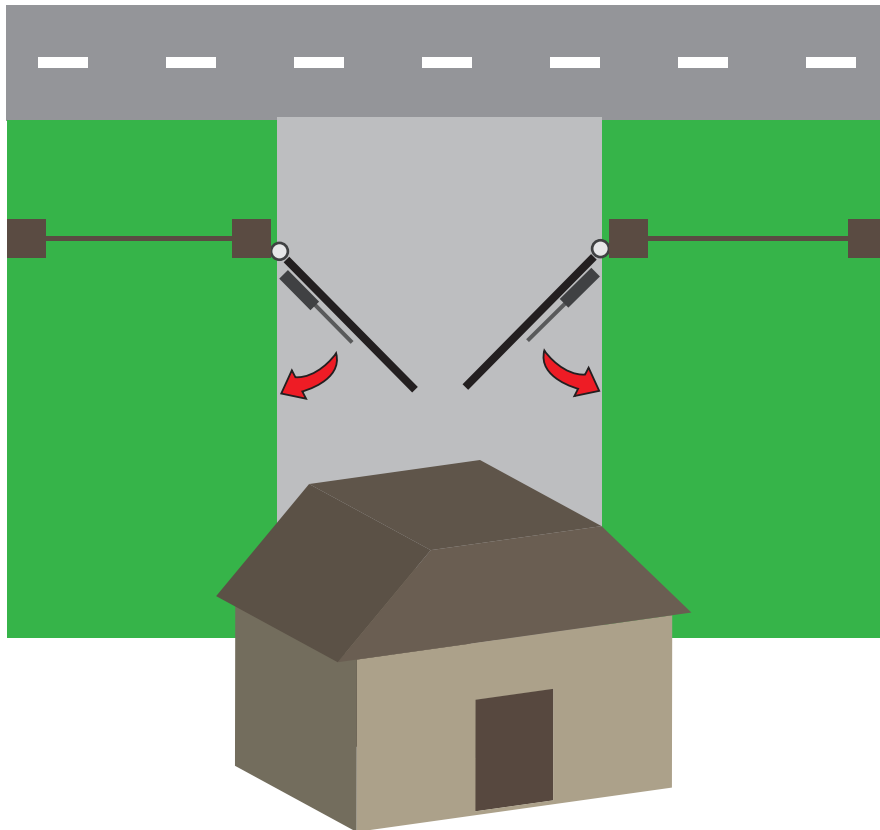

Wiring the Operator Arm(s)

For a dual gate use the provided wire to connect the secondary motor to the control board.

Push to Open
(Opening out towards the street)

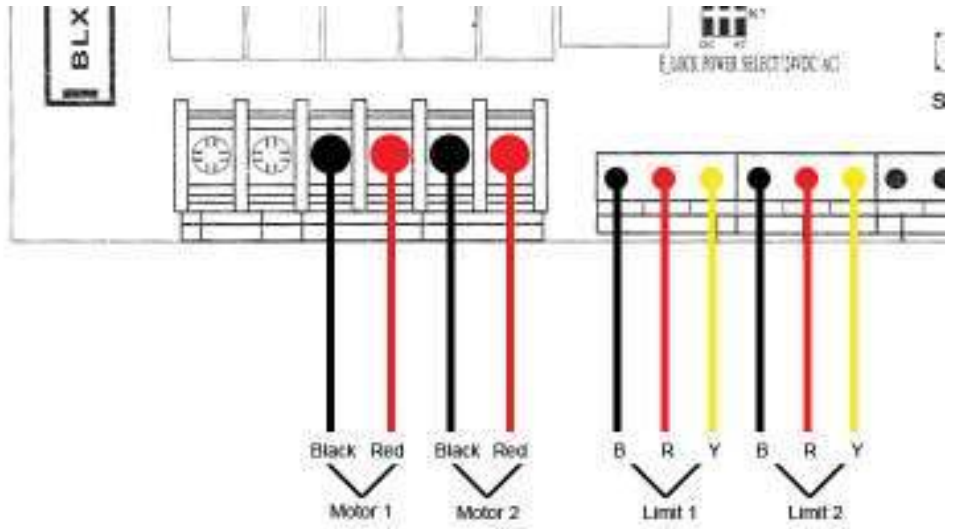

It is important to choose the correct operation type

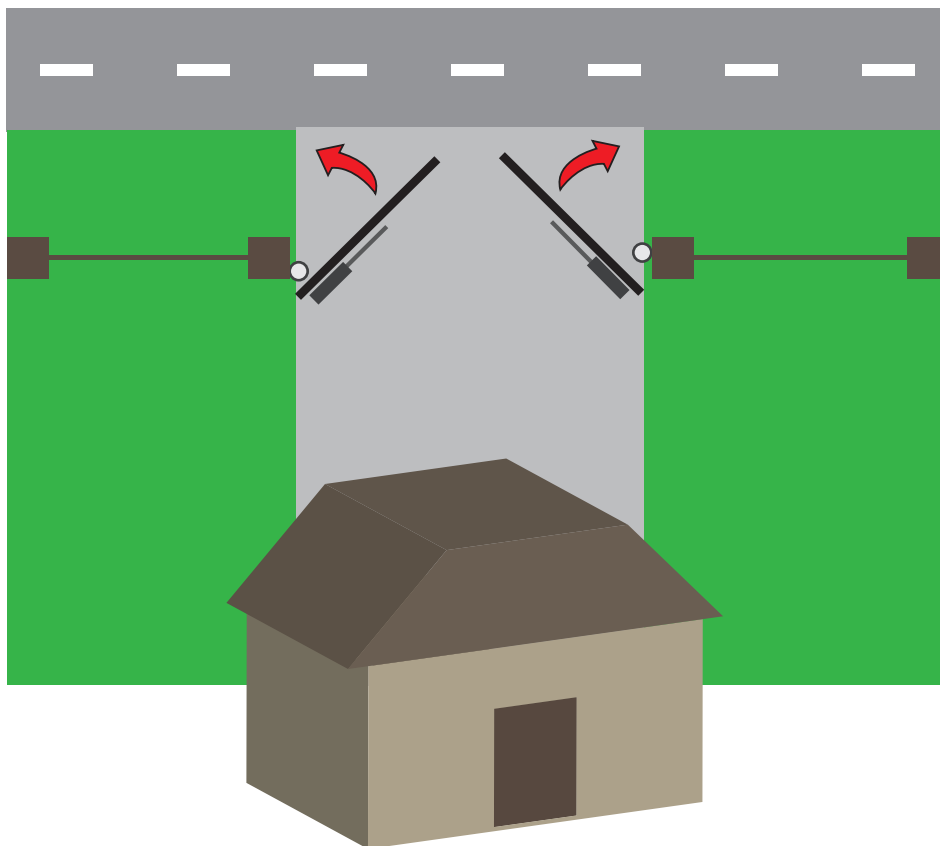

Temporary Safety Jumpers & Dip Switch Settings

If you are not using a safety device like a photo eye or safety loop the Photocell terminal must remain jumped to the GND terminal.

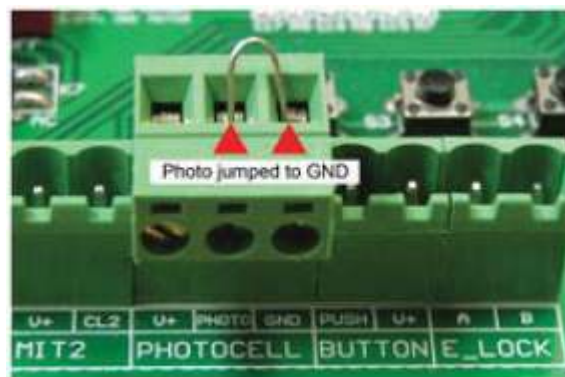

Dip Switches—To change any dip switches, you must turn the power off before changing the setting.

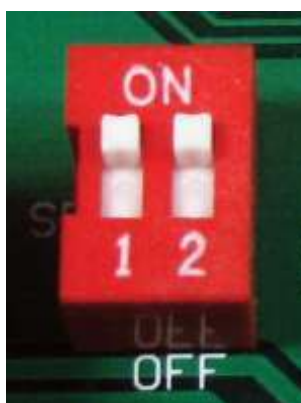

- 1.** ON: Auto-close on (the gate will re-close from the open position after a time set in the programming section)
OFF: Auto-Close off
- 2.** ON: Dual gate opener (2 motors)
OFF: Single gate opener (1 motor)



IMPORTANT: We recommend before turning the gate opener on for the first time to have dip switch 1 OFF. If the dip switch is set to on, the gate will autoreclose after turning it on without any intentional activation on your part.



Need more help?
Scan this code with your smartphone to view a supplementary video. Or go to:
<http://youtu.be/q13plsw6DxM>



Power

The Estate Swing E-S 300 comes with 1) 24V transformer. The transformer supplied has 2 screw terminals to connect to. You may locate the transformer up to 200' away from the control board using 16 gauge, 2 conductor stranded direct burial low voltage wire. Do not use solid core wire.

Allow a minimum of 4' of wire between the transformer and the control board.

Insert the two wires from the transformer into the two TRAN terminals on the control board. The wires are not polarized, there is no positive or negative. Do **NOT SPLICE THE POWER CABLE WIRE.**



Never run 110VAC power directly to the Estate Swing.

This will destroy the Estate Swing control board.

Never connect the power wire with the transformer plugged in. Contact between the two lead wires, even for a second, will destroy the transformer. Transformers are only warranted if the internal fuse is not blown. If the fuse is blown an outside factor (shorting, surge, water, etc) has caused the transformer not to function.

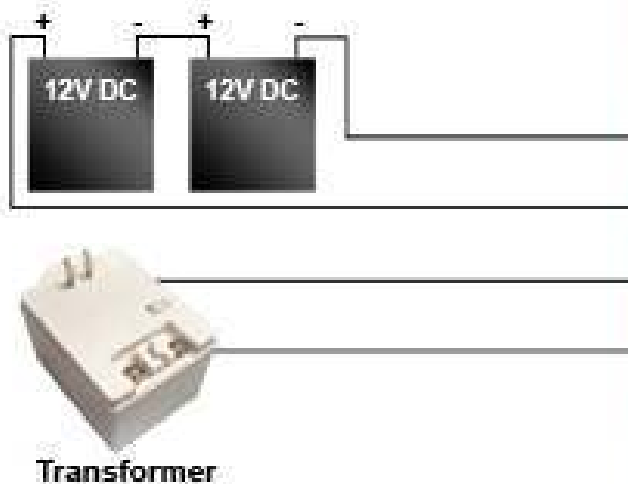

Plug the transformer into a 110 V AC outlet.

The transformer is not weather proof and must be kept in a covered area. Plug covers are available from your dealer, contact 1-800-640-GATE for a dealer in your area.

Two 12V DC batteries (Max 5 a/h per battery) may be run in series as backup to the 24V transformer power. Running two 12V batteries in series creates a 24V system, you cannot run them in parallel (see diagram above)

When you install new batteries - manually open the gate and allow the batteries to charge for 12 hours through the system before using the gate opener.

Section 4:

Start Up & Operation

Find Limit Positions

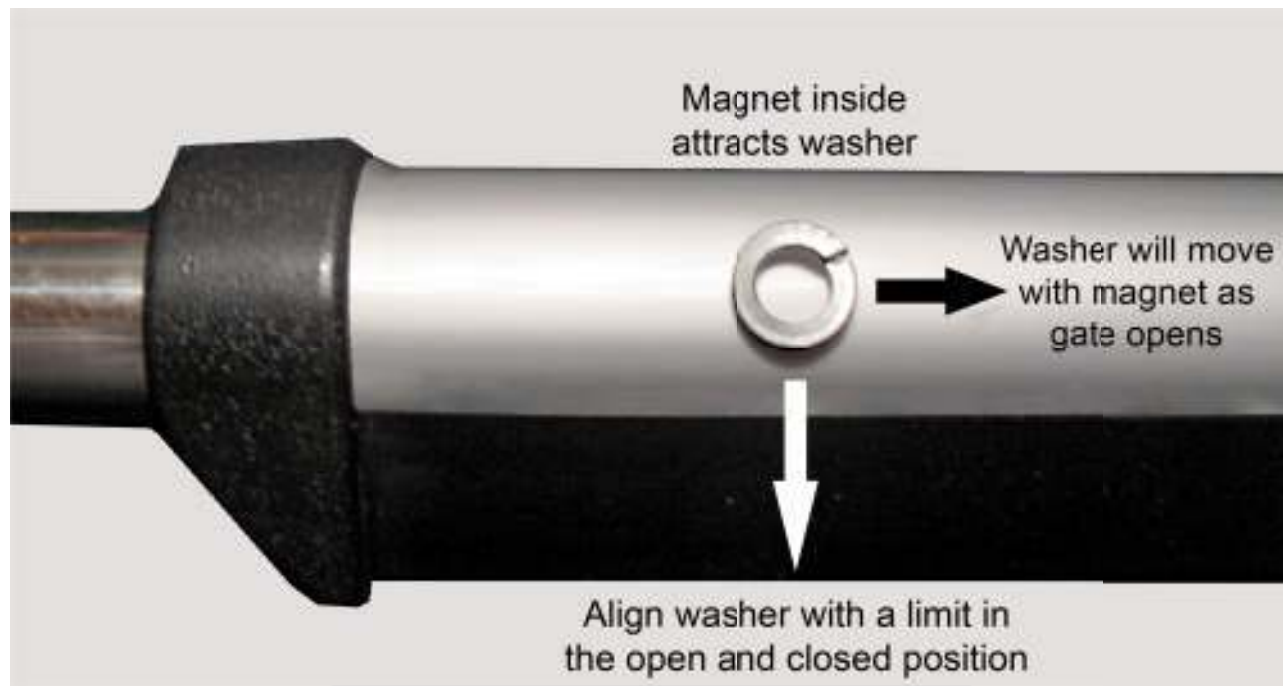

Example of washer and magnet in closed position (open for push-to-open)

1. Manually release the gate and move the gate to the desired closed position.
2. Take a metal washer and drag it along the side of the grey shaft until it is attracted by the internal magnet.
3. Move the limit switch on the bottom to line up with the washer. Underneath the arm there are slides secured with Philip head screws. After loosening the screws the switches will be able to slide. (picture of limits on page 4.3)
4. Move the gate to the open position and repeat with the open limit switch (as you open the gate you can leave the washer on the side and it will move along with the magnet).

Example of washer and magnet in open position (closed for push-to-open)



Need more help?

Scan this code with your smartphone to view a supplementary video. Or go to:
<http://youtu.be/VMqnihLtPP8>



First Run

This is our recommended procedure to run the gate for the first time.

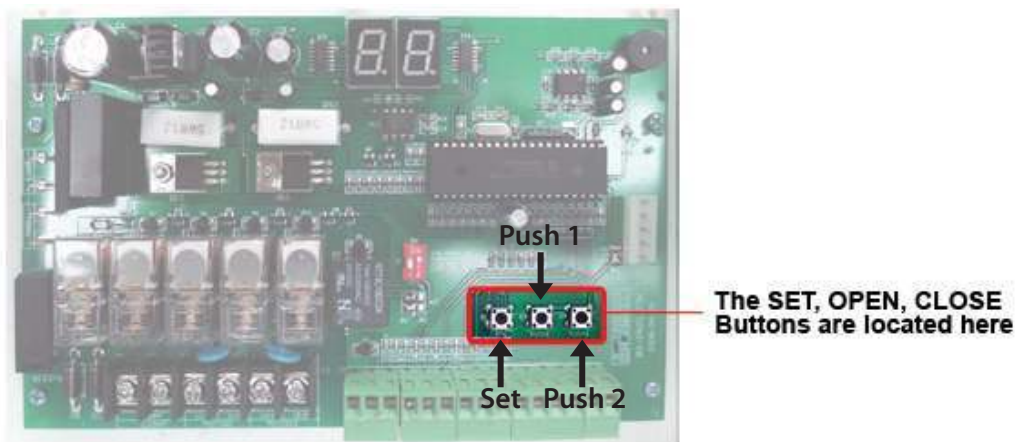

PUSH 1 or PUSH 2 to increase or decrease the parameter. Then press SET button to move to the next parameter.

1. Press SET button to begin.
2. LED shows P1: **Press Push 1 to get P1 setting to 30.**
3. Press SET button.
4. LED shows P2: **Press Push 1 to get P2 setting to 10.**
5. Press SET button.
6. LED shows P3: **Press Push 1 to get P3 setting to 30.**
7. Press SET button.
8. LED shows P4: **Press Push 1 to get P4 setting to 3.**
9. Press SET button.
10. LED shows P5: **Press Push 1 to get P5 setting to 10.**
11. Press SET button.
12. LED shows P6: **Press Push 1 to get P6 setting to 2.**
13. Press SET to finish. You should hear 3 beeps; this indicates parameter programming is finished.



Manually unlock the gate, then move it half-way and re-engage. Activate using Push 1 button (as shown above) The gate should run open. Press Push 1 again and it should run closed.

The gate is now set up for regular usage.



Need more help?

Scan this code with your smartphone to view a supplementary video. Or go to:
<http://youtu.be/ttgmyqDEixE>



Determine Run Time

Once you complete the first run, press the button and actuate your gate a few times. When the gate stops on the limits: If the gate has stopped short of or further than desired position, adjust the limit switches:

After you have your limits in the correct position secure the position of the switches with the screws and run your gate through a few cycles. On the display you will see a count while the arms are moving. This is your run time. Record your run time below.

ACTUAL RUN TIME: _____



Operating Parameters Customization

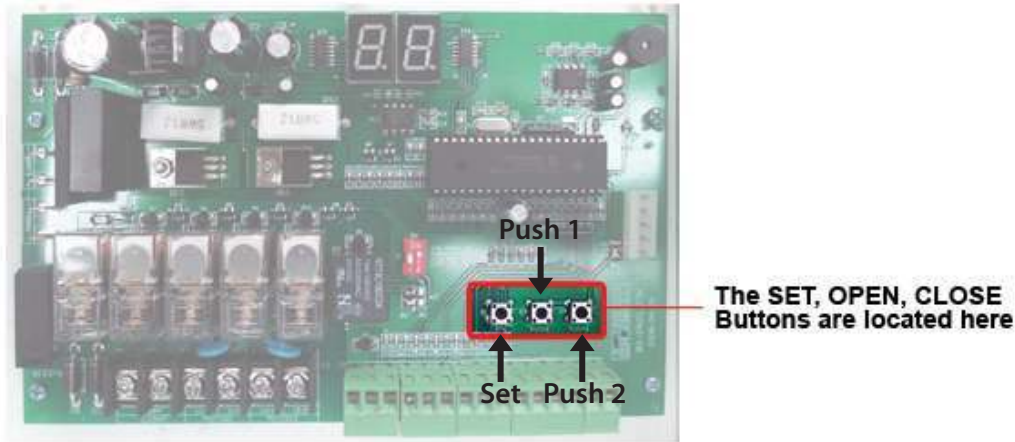

1. LED shows P1: **P1 is for setting your run time.** The run time will be determined from the time you had determined during the set up of the limit switches. Take that determined run time and add 1 second. So if it takes 10 seconds to get from closed to open between limit switches; set the run time to 11 seconds. The options are 0-99 seconds.
2. LED shows P2: **P2 is for setting your slow down time.** The gate opener will slow down to half speed after the time set on P2 expires. If you wish to have the gate open and close faster make the slow down start time a longer period of time. If you want to put less stress on the gears and gate set the slow time shorter to slow the momentum sooner. The options will adjust to match the previously set run time. NOTE: *motor must be in slow down to detect limits—be sure this number does not exceed the time the motor take to move from one limit to the other.*
3. LED shows P3: **P3 is the force setting**, the lower the number the easier the gate will reverse directions when it meets resistance. This number may have to be changed to a higher setting if your gate is obstructing unexpectedly. The number should be set to the highest number during initial setup and reduced to the point of reliable operation that takes into account change in gate resistance through out the year. The options are 0-32.
4. LED shows P4: **P4 is for setting a delay between leafs** if you have overlapping gates or a gate lock. The motor wired into the master terminals (1) opens first if there is a delay and closes second. It is recommended to have a delay of 3 seconds to avoid any jamming issues between leafs.
5. LED shows P5: **P5 is the delay for automatic re-close** from the open position – this option needs to be turned on using the dip switch on the board. The options are 0-99 seconds.
6. LED shows P6: **P6 is the release for the gate lock** – this option determines the length of time 24VDC will be sent out of terminals E_LOCK. *The options are 1-4 seconds.*

Section 5:

Maintenance, Troubleshooting & Accessories

Maintenance

- 1) Lubricate the rear pivot and front pivot of the bracket.
- 2) Lubricate the gate hinges about every 3 months, and also check for levelness of gate.

Rear Pivot



Front Pivot



Troubleshooting

If the gate opener will not move but the board is counting the run time:

- Check wiring connections.
- Be sure the arms are locked and not in manual operation.
- If not using slave limit switches, be sure jumpers are in place.
- Check the left hand fuse near the power supply—the proper way to inspect a fuse is to remove it from its clips and check for continuity.

If the gate opener moves a few inches or feet and stops or reverses directions:

- Increase the force setting (P3).
- Check the setback. The setback of the operator is important to correct operation due to leverage the arm will have on the gate.
- Check the battery voltage. Proper voltage should be between 13.4 – 13.8 and drop no more than a quarter of a volt under load.
- Disconnect accessories that may be triggering the gate a second time. The most frequent issues are from exit sensors or other automatic opening devices.

The gate does not reach the desired stop points:

- Adjust the limit switches.
- Lengthen the run time parameter (P1).
- Check setback— if setback is incorrect it will limit how far the gate will move per inch of stroke length.

If the gate will open but will not close:

- Manually move the gate slightly off the open position and then trigger the gate to go closed. If the gate then moves closed the limits are most likely wired backwards. (Meaning the open limit is wired to closed and closed wired to open)
- If you are **not** using safety devices the safety jumpers are in place. If PH is on display it is an issue with the safety jumper or a device in the safety terminals.
- If you are using a safety device:
 - Check to make sure you are using the normally closed connection instead of the normally open.
 - Check to be sure there is continuity being provided between the common and normally closed wire of the safety device. If there is not continuity then refer to the installation guide of the device to set up properly.

The display of the board will not light up:

- Check the power supply for 24VAC.
- The arms are not wired in or properly wired on the limit switch connections. Without the limit switch connections being closed the board will not light up.

More on next page

Troubleshooting

The gate opener is not stopping on the limit switches:

- Remove all pre-installed jumpers from the limit switch terminals that have limits going to them. The slave gate terminals come pre-jumped for single operation, if you are using a dual system pay particular attention to this detail and remove the jumpers when you put your limit switches in.
- The limits are wired incorrectly—be sure that you are following the correct wiring diagram for pull to open or push to open.
- For dual gates check that the delay between leafs is 2 or above. If both limits are triggered simultaneously there is a chance a limit could be missed.

One or both arms are not moving:

- Check to be sure wiring color pattern matches the installation (Example: push to open wiring for a push to open installation) - If the limits or motor are wiring opposite the installation the board will believe it is closed or open when it is actually the opposite and the arms will never move.
- Check the limit wires are correctly in the terminal blocks. The terminal blocks come with the terminal clamps closed - however when the terminal clamps are closed there is a small space below them one could mistake as place to insert a wire. If this is done then conductivity of the connection will never be reached.
- Push or pull on the gate - if it moves the gears are disengaged and the gate is in manual release mode.

General fix for user to understand operation:

- Unlock the gate opener arm and move it to the half way position. Change the run time to a low number (example: 2). Run the operator repeatedly.
- The operator should run one direction for a 2 count and then the other for a 2 count. After you feel you have it following the run time correctly and swinging level and easily, then start incrementally lengthening the run time.
- Eventually the run time will allow the operator arm to reach both limit switches and your setup is complete.

Dual gate - Only one arm moves:

- Check your dual settings - if the dip switch is changed to dual with the power on the setting will not take effect, turn the power off and then back on to have the dual dip switch take effect. *NOTE: If one leaf of a dual gate ever reaches its end limit before the other leaf starts moving, the leaf that hasn't started moving will not begin: correct this by cycling the gates again and let it travel the full stroke or decrease the delay between leafs. The options are 0-9 seconds delay.*



Need more help?

Scan this code with your smartphone to view a supplementary video. Or go to:
<http://youtu.be/3yOSogiSLeY>



Troubleshooting



IF YOU CALL IN FOR TECHNICAL SUPPORT OR WARRANTY SUPPORT: Before any control board or motor will be permitted to be sent in for testing or warranty you will be required to e-mail digital photos to the technician.

This is done in your best interest to save unnecessary shipping expenses and time lost. Many times we can come up with solutions to issues by seeing pictures that relay information that is impossible to relay through a phone conversation.

Below are examples of control board pictures and motor pictures that we will be looking for:



Pictures shown are actual customer photos

Control Board Overview



CAUTION! Do not run 110V AC power direct to the board. This will cause permanent damage to both boards and void your warranty. Caution!

Gate Opener reactions to signals:

PUSH1 and Receiver (PUSH 1 terminal, PUSH 1 button, 5 Prong Receiver):

Details:

- Will activate gate with momentary contact (momentary contact between PUSH1 and V+) or if you momentarily press the PUSH1 button.
- Controls both leaves in 2 leaf mode (Dip switch 2 in the ON position).
- Acts as party mode control to suspend auto-reclose by activating while counting down autoreclose in the open position.

Operational Sequence for terminal with autoclose ON (Dip switch 1 in on position):

1. In closed position - momentary contact will open gates.
2. When opening - momentary contact will stop gates and then it will auto reclose.
3. When stopped mid cycle waiting auto reclose - momentary contact will move the gate in the direction opposite what it was moving before stopped.
4. When open and counting auto-reclose pause time - momentary contact will stop pause time.
5. Stopped in open position from override of auto-reclose from PUSH1 or Receiver - momentary contact will reactivate pause time and close gate.
6. When closing - momentary contact will stop the gate and then it will auto reclose.

Operational Sequence for terminal with autoclose OFF (Dip switch 1 in off position):

1. In closed position - momentary contact will open gates.
2. When opening - momentary contact will stop gates.
3. When stopped mid cycle - momentary contact will move the gate in the direction opposite what it was moving before stopped.
4. When open - momentary contact will close gates.
5. When closing - momentary contact will stop the gate.
6. When stopped mid cycle - momentary contact will open the gate.
7. When open with auto-reclose off - momentary contact will have no effect.
8. When closing - momentary contact will re-open the gate.

Control Board Overview



CAUTION! Do not run 110V AC power direct to the board. This will cause permanent damage to both boards and void your warranty. Caution!

Gate Opener reactions to signals:

PUSH2 (PUSH 2 terminal and PUSH 2 button):

Details:

- Will activate gate with momentary contact (momentary contact between PUSH2 and V+).
- Controls **both** leaves in 2 leaf mode (Dip switch 2 in the ON position)
- **Only opens the gate, never closes it.**
- Pause time is able to be re-set if this terminal is closed through a momentary contact. Then the time will be reset, count down the pause time, and reclose.
- **Ideal for exit wand or exit loop.**

Operational Sequence for terminal with autoclose ON (Dip switch 1 in on position):

1. In closed position - momentary contact will open gates.
2. When opening - momentary contact will have no effect.
3. When stopped mid cycle from PUSH 1 or the Receiver - momentary contact will open the gate.
4. When open with auto-reclose on - momentary contact will re-set pause time and will start counting again after release of momentary contact.
5. When pause time countdown is stopped in open from a momentary contact of PUSH 1 or the Receiver - momentary contact will have no effect.
6. When closing - momentary contact will re-open the gate.

Operational Sequence for terminal with autoclose OFF (Dip switch 1 in off position):

1. In closed position - momentary contact will open gates.
2. When opening - momentary contact will have no effect.
3. When stopped mid cycle - momentary contact will open the gate.
4. When open with auto-reclose off - momentary contact will have no effect.
5. When closing - momentary contact will re-open the gate.

PUSH 1 and PUSH 2 – these terminals can hold as many normally open connections as needed, they will be wired in parallel. They are used for keypads, push buttons, universal receivers, etc.

Control Board Overview

Light: Sends pulses of 24VDC only while gate is running, and whether it is open or closed.

Motor 1: L1-1, L1-2 = 24VDC power to single motor or master motor

Motor 2: L2-1, L2-2 = 24VDC power to slave motor

Limit 1: OL1 = Open limit for single motor or master (normally closed)
V+ = Common for limits, +12VDC
CL1 = Closed limit for single motor (normally closed)

Limit 2: OL2 = Open limit for slave motor (normally closed)
V+ = Common for limits, +12VDC
CL2 = Closed limit for slave motor (normally closed)

Photocell: V+ = +12VDC, Max 100 milliamps for photocell power
Photo = Input for safety eye photo beam connection (normally closed)
GND = Ground for photocell power/ground for photo connection

Button: PUSH 1 = Ground for Push 1 Accessory
V+ = Positive voltage +12VDC for Push 1 accessory (relay only, not main power)

**PUSH 1 / V+ is for push buttons, keypads, receivers, or any other dry and momentary contact.*

PUSH 2 = Ground for Push 2 accessory
V+ = Positive voltage +12VDC for Push 2 accessory (relay only, not main power)

**PUSH 2 / V+ is for exit wand, exit loops or other open only dry contact and momentary contact*

E_Lock: Solenoid lock output - 12VDC (4 Amp max)
A = Positive B = Negative

Fuses: F1 = 8A 250V, protects incoming power to board.

Control Board Overview



CAUTION! Do not run 110V AC power direct to the board. This will cause permanent damage to both boards and void your warranty. Caution!

Lights off on board & stand by / normal operation

Lower right hand “dots” flashing normal pace:

Active / Awaiting command

Display

Indicators:

EL: Sending voltage to EL terminals (electric lock)

OP: Opening cycle

AU: Auto-reclose countdown

CL: Closing cycle

Buzzer/

Obstructions:

If the gate(s) come in contact with an obstruction the gate(s) will reverse direction for 2 seconds and stop to allow the obstacle to be cleared from the gate path.

If the gate(s) obstructs 3 times in a row the gate(s) will go into a hard shutdown mode and a buzzer alarm will sound. At this point no accessories or remotes will be able to activate the gate opener until the gate opener is reset by disconnecting primary power battery.

Installing Accessories

Accessory manuals for most make and model accessories can be found on the web at:

www.EstateSwing.com/accessories

The accessory manuals you have or find at the above address may be written to coincide with that manufacturer's model of gate opener. To determine correct terminals on your Estate Swing operator, use the accessory terminal section of your Estate Swing manual. The following are some common terms and abbreviations found in manuals:

Normally Open – abbr. N/O – Indicates a circuit that is left open during normal operation of the gate operator. When a device closes this circuit it signals the operator to perform a function. This circuit is the main circuit for entry devices. (i.e. keypads, exit wands, push buttons, etc.)

Normally Closed – abbr. N/C – Indicates that in order for the gate opener to be active this circuit must be closed. When a device opens this circuit it stops the motion of the gate operator. This circuit is the main circuit for safety devices. (i.e. photo eyes, safety loops, etc.)

Common – abbr. COM – This is the matching terminal for both Normally Open and Normally Closed circuits to be connected to. Accessory wiring that begins in a N/O or N/C terminal must have a wire that ends in a Common terminal.

Ground – abbr. GND or GRD – Ground is sometimes also known as negative. Common terminals are the same as Ground terminals. Ground can also be the negative spade of the battery if it is being used in association with positive voltage.

If a device has both a N/O and a N/C wire, both are never used at the same time. Some devices can be used as either an opening device or a safety device (i.e. gate crafters exit wand, NIR photo eye, etc.) If being used as an opening device use the N/O and if being used as a safety device use the N/C terminals.



Need more help?

Scan this code with your smartphone to view a supplementary video. Or go to:
<http://youtu.be/COyG06XXm4Q>

